

THIS SPACE FOR DESIGNER/ENGINEER APPROVAL

Job/Customer _____	Date _____	Contractor _____
Model Specified _____	Qty _____	Approved By _____
Designer/Engineer _____	Date _____	Contractor's PO# _____
Submitted by _____	Date _____	Other _____

5041 Series

**Full Port Forged Brass Uni-Flange Ball Valves
w/ Hi-Flow Hose Drain
Bonus Wing Style "T" Handle, Nuts & Bolts
SWT x Flange
600 WOG – ISO 9001**



**The Only Way To
Isolate Circulator Pumps**

ITEM #	SIZE	CTN	CASE	A	B	C	D	E	F	G	H	I	J
50413	3/4"	2	20	3/4	3 3/4	2 1/4	4	3/8	1/2	1	2 11/16	4 1/8	1/2
50414	1"	2	20	1	3 15/16	2 5/8	4 5/8	3/8	1/2	1 1/4	2 11/16	4 1/8	1/2
50415	1 1/4"	2	20	1 1/4	4 1/4	3	4 5/8	3/8	1/2	1 9/16	2 11/16	4 1/8	3/4
50416	1 1/2"	2	10	1 1/2	5 1/2	3 1/4	5 1/2	3/8	1/2	1 15/16	2 11/16	4 1/8	3/4
50414HV	1"	2	20	1	3 15/16	2 5/8	4 5/8	3/8	5/8	1 1/4	2 11/16	4 1/8	1/2
50415HV	1 1/4"	2	20	1 1/4	4 1/4	3	4 5/8	3/8	5/8	1 9/16	2 11/16	4 1/8	3/4
50416HV	1 1/2"	2	10	1 1/2	5 1/2	3 1/4	5 1/2	3/8	5/8	1 15/16	2 11/16	4 1/8	3/4
50417HV	2"	1	10	2	5 1/2	3 1/4	5 1/2	3/8	5/8	1 15/16	2 11/16	4 1/8	3/4



**PATENTED
TECHNOLOGY**

NO.	DESCRIPTION	MATERIAL
1	BODY	BRASS
2	END CAP	BRASS
3	SEATS	PTFE
4	BALL	BRASS HCP
5	STEM	BRASS
6	STEM SEAL	PTFE
7	PACKING GLAND	BRASS
8	LEVER HANDLE	STAINLESS STEEL
9	HANDLE NUT	STAINLESS STEEL
10	HANDLE JACKET	VINYL
11	SEAT RETAINER	BRASS
12	DRAIN END CAP	BRASS
13	DRAIN SEATS	PTFE
14	DRAIN BALL	BRASS HCP
15	DRAIN STEM	BRASS
16	DRAIN STEM SEAL	PTFE
17	DRAIN PACKING GLAND	BRASS
18	DRAIN HANDLE	ENAMEL COATED ALUMINUM
19	DRAIN HANDLE SCREW	BRASS
20	WASHER	EPDM
21	CAP AND STRAP	BRASS W/ EPDM STRAP
22	FLANGE BOLTS AND NUTS	STEEL ZP
23	WING STYLE "T" HANDLE	STAINLESS STEEL

TEMP °F	WOG
100	600
150	485
200	395
250	210
300	N/A
350	N/A
366	N/A

Webstone Company, Inc.
www.webstonevalves.com

Quality and Commitment Since 1954

Tel: (800) 225-9529 • Fax (800) 336-5133

Webstone product specifications in U.S. customary units are approximate and are provided for reference only. Webstone reserves the right to change or modify product design, construction, specifications or materials without prior notice and without incurring any obligation to make such changes and modifications on Webstone products previously or subsequently sold.

THIS SPACE FOR DESIGNER/ENGINEER APPROVAL

Job/Customer _____	Date _____	Contractor _____
Model Specified _____	Qty _____	Approved By _____
Designer/Engineer _____	Date _____	Contractor's PO# _____
Submitted by _____	Date _____	Other _____

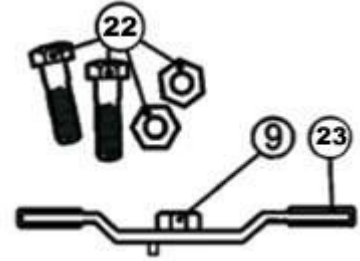
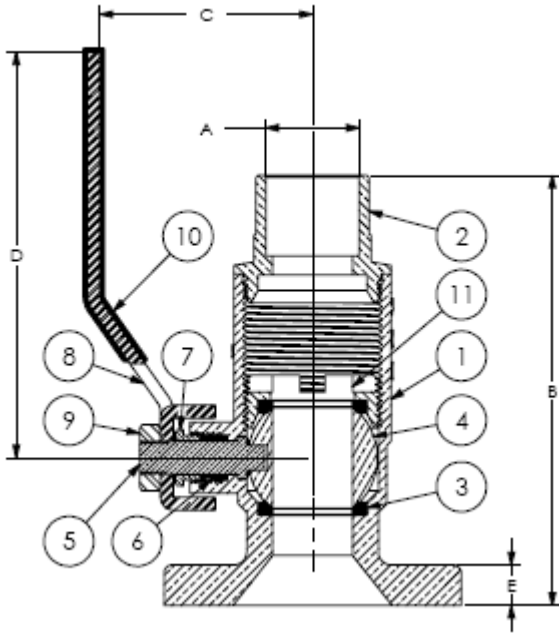

FLANGE FOR REGULAR MODELS

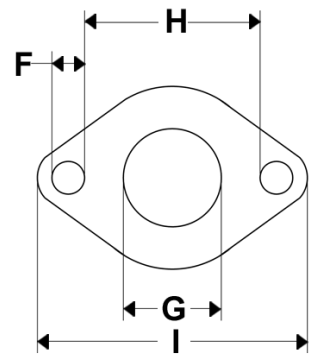

FLANGE FOR HIGH VELOCITY PUMP MODELS

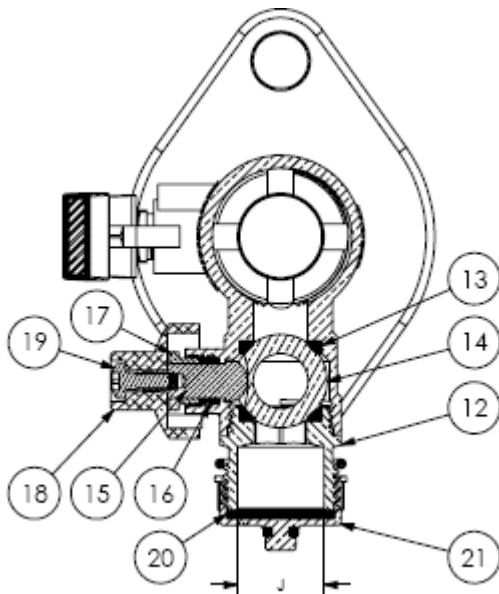
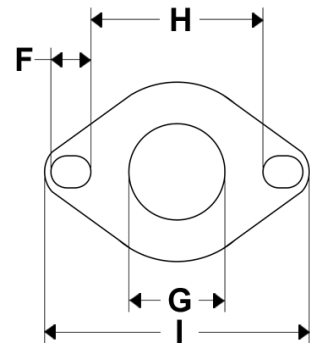

Specifications: Designed for residential, commercial or industrial use with water, oil or gas. This approved Webstone valve is actuated by a blowout proof stem and features an adjustable packing gland. Solder joint temperature ratings are per ASME B16.18 Annex A for 95-5 solder. Other solder materials have lower pressure/temperature limits. Do not silver braze or over heat valves when soldering.

Webstone Company, Inc.
www.webstonevalves.com

Quality and Commitment Since 1954

Tel: (800) 225-9529 • Fax (800) 336-5133

Webstone product specifications in U.S. customary units are approximate and are provided for reference only. Webstone reserves the right to change or modify product design, construction, specifications or materials without prior notice and without incurring any obligation to make such changes and modifications on Webstone products previously or subsequently sold.