



**THE MOST
TRUSTED
OUTDOOR
STOVES**

PRISTINE SERIES

OWNER'S MANUAL
SAVE THESE INSTRUCTIONS

INSTALLATION, OPERATION & MAINTENANCE



2716 CRESCENT DR. | PO BOX 1237
INTERNATIONAL FALLS, MN 56649
866-361-7355 | WWW.CROWNROYALSTOVES.COM



UL 2523 AND
CSA B366.1



PROTECT YOUR INVESTMENT

COMPLETE YOUR WARRANTY ONLINE TODAY

Greentech Manufacturing Inc. offers to the original owner from date of purchase a limited twenty (20) year warranty. **To validate this warranty, without exception, you must:**

1. Complete the online warranty form, accessible by the QR code below or at www.crownroyalstoves.com/warranty-registration
2. Perform yearly water samples (information below)

If, for any reason, you are unable to fill out your stove registration online please call us at 866-361-7355 and we will send you a warranty registration form.

YEARLY WATER TESTS REQUIRED FOR WARRANTY

SIGN UP FOR REMINDERS

Purchaser must use Crown Royal Stove's approved chemical treatment **and** mail water samples to our third party testing facility within 30 days of purchase. **Warranty is void if our chemical is not used and the boiler water is not tested at least annually.** You will get notification of test results by email (if listed) or mail within 30 days. If you are not notified within 30 days you need to contact us. If test results come back unsatisfactory, you are required to follow the instructions and retest within 30 days. If you add water to your system for any reason add ½ ounce of chemical per gallon of water and send a new sample of water to the testing laboratory. For further information visit www.crownroyalstoves.com/water-treatment

ONLINE WARRANTY



WATER TEST REMINDERS



TABLE OF CONTENTS

INTRODUCTION	5
BEST BURN PRACTICES.....	6
ADDITIONAL INSTALLATION AND OPERATIONAL CONSIDERATIONS	7
GUIDE TO BURNING WOOD	8
SAFETY INSTRUCTIONS & PRECAUTIONS.....	9
PRECAUTIONARY LABELING	10
INSTALLATION	11
FURNACE FLOOR PLAN.....	13
CHIMNEY	14
TRANSFER LINE - INSTALLATION	15
INSTALLATION	16
EXISTING HOT WATER HEAT INSTALLATION.....	17
DOMESTIC HOT WATER & FORCED AIR INSTALLATION	18
BRAZED PLATE SETUP - INSTALLATION.....	19
WATER TO AIR SET UP - INSTALLATION.....	20
STOVE COMPONENTS	21
CONTROL PANEL.....	23
START UP & OPERATION	24
OPERATION.....	25
WEEKLY MAINTENANCE.....	27
GENERAL MAINTENANCE	28
TROUBLESHOOTING.....	30
ELECTRICAL WIRE DIAGRAM	31
HPBA SMOKE TROUBLESHOOTING CHECKLIST	33
AUTHORIZED FURNACE TREATMENT	38
FURNACE TREATMENT PROCEDURE.....	39
MANDATORY WATER TREATMENT & TESTING	40
EMERGENCY PROCEDURE FOR CHEMICAL.....	41
20 YEAR LIMITED WARRANTY	42
WARRENTY CLAIM FORM	43
ELECTRONIC TEMPERATURE CONTROL MANUAL (16E09-101)	46

Greentech Manufacturing would like to thank you for your recent purchase of a Crown Royal Stove. We sincerely appreciate the trust you have placed in us and we look forward to continuing to serve you. We know that you will be pleased with our continued commitment to your satisfaction while you enjoy the benefits of heating with a Crown Royal Stove. Crown Royal Stoves are manufactured with quality workmanship and designed to offer you value now and for years to come. We are so confident in the quality of our furnace each Crown Royal Stove comes with a 20 year limited warranty.

To ensure maximum benefits from your furnace, read the complete manual prior to using or installing your furnace.

Always keep this manual for future references.

Crown Royal Stoves – EPA 2020 Step 2 Certified

U.S. ENVIRONMENTAL PROTECTION AGENCY Certified to comply with the 2020 particulate emission standards using cord wood.

7200E: Tested to ASTM E2618-13, average emission rate .08 lbs/mmbtu, maximum emission rate 0.120 lbs/mmbtu.

7300E: Tested to ASTM E2618-13, average emission rate .08 lbs/mmbtu, maximum emission rate 0.118 lbs/mmbtu.

7400E: Tested to ASTM E2618-13, average emission rate .06 lbs/mmbtu, maximum emission rate 0.069 lbs/mmbtu.

The outdoor series furnaces are designed to be located next to your firewood storage for convenience and is normally filled once or twice a day, depending on the temperature outside. Our outdoor series furnaces are often used to heat residential home, garages, shops, barns, businesses, greenhouses, swimming pools, spas, domestic hot water, radiant in-floor heat, and snow melt applications.

Model	7200E	7300E	7400E
Estimated Btu's*	125,000	221,000	325,000
Heating Capacity**	2,000-3,000 sq ft	4,000 – 5,000 sq ft	8,000-10,000 sq ft
Dimensions (L X W X H)	70" x 47" x 71-1/2" plus chimney length	76" x 49" x 80-1/2" plus chimney length	84" x 53" x 86-1/2" plus chimney length
Approx Weight	1950 lbs	2650 lbs	2950 lbs
Firebox Length	28"	32"	36"
Wood Load Capacity	26"	30"	34"
Chimney Size	6"	6"	8"
Firebox Door Size (L X H)	18" x 18"	20" x 24"	22" x 26"
Supply/Return Size	1-1/4" (1 Each)	1-1/4" (2 Each)	1-1/4" (2 Each)
Water Capacity	180 Gallons	235 Gallons	290 Gallons
Electrical Rating	115 VAC/60HZ/1 PH	115 VAC/60HZ/1 PH	115 VAC/60HZ/1 PH

*Btu's are estimated and will vary with the type of wood burned.

**Ensure to properly size unit to buildings thermal demands.

Crown Royal High Efficiency Wood Gasification Furnaces are designed to burn only clean, dry wood. Clean wood means wood that has no paint, stains, or other type of coatings. It also includes wood that has not been treated with preservatives, including but not limited to, copper chromium arsenate, creosote or pentachlorophenol. Wood must be cured between 6-9 months and dried to 20% moisture or less.

Warranty will be voided if the furnace is used to burn materials for which the unit is not certified by the EPA and void if not operated according to the owner's manual. Burning any other material other than "Clean, Dry Wood" will VOID warranty.

For Outdoor Use Only!

This wood heater needs periodic inspection and repair for proper operation. It is against federal regulations to operate this wood heater in a manner inconsistent with operating instructing in this manual.

Learn how to get the best burn possible from your Crown Royal Stove.

Instructions – Read and follow all operating instructions supplied by Greentech Manufacturing, Inc.

Fuels – Only burn clean wood, which is the only approved fuel in your Crown Royal Stove. Burning materials not recommended play a major role in visible emissions. Never burn: trash, plastics, gasoline, rubber, naphtha, household garbage, material treated with petroleum products, particle board, railroad ties, pressure treated wood, leaves, paper products and cardboard.

Loading of Fuels – Burning wood creates visible emissions. In order to complete the combustion process, there is a minimum amount of space needed. For instance, if a person were to load a relatively small firebox completely and load a larger firebox with the same amount of fuel, with all of the other factors being the same, the larger firebox would burn cleaner. In the smaller firebox, the combustion process does not have enough room to expand heat up and mix before exiting the firebox (insufficient time, temperature and turbulence). Just because a firebox is large does not mean that it should be filled completely. This large volume is used in part for what happens after it is loaded. Fireboxes should be loaded based on outdoor temperatures, and anticipated heat load required to maintain sufficient levels to ensure the fire doesn't go out before next fill.

Starting – Always start fire with wood kindling to eliminate unnecessary smoke. Never use gasoline, lighter fluids, chemicals, or oils.

Furnace Sizing – The size of a furnace should be large enough to provide sufficient heat without constant reloading. Targeted burn times are around 12 hours; an adequately sized furnace will provide enough heat for 90% of all heating days. Inadequate size of furnace will lead to unattended fires that leave colder fireboxes and relighting will be dirtier because the flame quenches on the cool firebox walls. A good rule to follow is that if the furnace cannot stay within 20% of its set temperature under regular reloading, then the unit is undersized and a larger furnace is needed.

Operation – Improper combustion air can be associated with several factors. The air inlet and chimney may be restricted by debris (creosote, ash, etc). The blower starts and stops properly and runs at proper speed. The door seal is in satisfactory condition.

Maintenance – Excessive creosote buildup can be a result of restricted air flow from combustion fan, flame baffle or chimney blockage.

Local and State Regulations – Always remember to comply with all applicable state and local codes.

DANGER!!! Do not start fire with chemicals, volatile fluids, rubber, plastics or garbage. Some processed wood contain resins and should be avoided. Only competent persons with a sound understanding of this heating method should operate this furnace. Improper firing could result in personal injury and/or damage to unit, and void warranty. Do not burn garbage, gasoline, drain oil, naphtha, engine oil, railroad ties, particle board, leaves, cardboard, or any other flammable liquids.

Installation

Person (s) operating a Crown Royal Stove must comply with all applicable laws or other requirements, such as state laws or regulations and local ordinances. Person (s) is/are also responsible for operation in a manner that does not create a public or private nuisance condition. The distance and stack height Greentech Manufacturing recommends and the requirements in any applicable laws or other requirements may not always be adequate to prevent nuisance conditions due to terrain or other factors.

The EPA offers tips on how to properly use a moisture meter to test firewood before using in a wood-burning stove or fireplace. Wet wood can create excessive smoke which is wasted fuel.

The EPA's Burnwise Program

<http://www.epa.gov/burnwise>

How to Use a Moisture Meter Video

<http://www.youtube.com/watch?v=jM2WGgRcnm0>

The EPA offers four simple steps to properly dry firewood before using in a wood-burning stove or fireplace. Wet wood can create excessive smoke which is wasted fuel. Burning dry, seasoned firewood with a moisture content of 20% or less can save money and help reduce harmful air pollution.

Split, Stack, Cover and Store Video

<http://www.youtube.com/watch?v=yo1--Zrh11s>

This tri-fold brochure provides colorful illustrations of the four easy steps to dry firewood.

Wet Wood is a Waste Brochure

<http://www.epa.gov/burnwise/pdfs/wetwoodwastebrochure.pdf>

The quality of the firewood you burn can have a big effect on the overall performance and efficiency of your furnace. The main factors that affect the burning characteristic of firewood are moisture, tree species, and size. It is important that you understand and follow our guidelines when choosing wood as a fuel source.

Fresh cut wood will have a moisture content between 35 and 50 percent by weight. If you try to burn wet wood, it will not only be difficult to ignite but will hiss and sizzle in the firebox. Burning wet wood consumes energy that will normally be used to efficiently complete the combustion process. Properly seasoned wood will ignite easily and burn efficiently. Hardwoods like oak and maple dry more slowly than softer woods like spruce and poplar. Properly seasoned wood would have a moisture content of less than 20%. Firewood dries slowly and may take a full year or more to season.

Ways to tell if firewood is dry enough to burn:

- Test wood with a moisture meter. Moisture meters can be purchased at a local hardware store for around \$25.00.
- Wood darkens with aging, from white or cream in color to yellow or gray.
- There are cracks in the end grain.
- Banging two pieces together, dry wood sounds hollow. While wet wood sounds dull.
- Split a piece and if the fresh surface feels damp and cool, the wood is wet. If it feels dry and warm it is seasoned.
- When you burn it, if it hisses, it is too wet.

Types of Wood:

Wood can be classified as softwood or hardwood. Pines, spruces and firs are common softwoods and oaks, elms, birches, and maples are hardwoods. Softwoods burn rapidly and are more resinous than the hardwoods; therefore, they will cause a greater creosote build-up. Hardwoods produce a long-lasting fire with uniform heat. Hardwoods are the most desirable and are used by the majority of wood burners.

Proper Wood Storage:

1. Cut the wood to the desired length. It should easily fit in your firebox.
2. Split your wood before stacking it – Splitting the wood in advance of stacking it increases exposure to air, which improves drying time.
3. Check the moisture content – Place the moisture meter tip into the longest side of a piece of split wood. (Goal is 20% moisture content)
4. Stack your wood in alternate directions – Spacing is needed to provide better circulation and helps in the drying process.
5. Store your wood off the ground – Store wood six inches or more off the ground to prevent moisture.
6. Cover wood, but leave the sides exposed – Use a tarp or best option is to build a structure that has a roof. If using a tarp, make sure your sides are open, so moisture is not trapped.
7. Properly seasoned wood could take up to 12 months or more to dry.
8. Storage of your wood must be in a debris free, dry environment that is at least sixty (60) inches from the front of the stove and thirty-six (36) inches from the sides or back of the stove.

Purchasing Wood:

A cord of wood is a ranked stack of logs 4' x 4' x 8'. Usually when you purchase firewood, it is sold by the "face cord". A face cord is a ranked stack of logs 4 feet high, 16 inches deep and 8 feet long. Wood is sometimes sold by the ton; a ton of dry hardwood is equivalent to approximately ½ full cord. Whenever possible it is best to burn hardwood that has been split and air dried for one year.

SAFETY INSTRUCTIONS & PRECAUTIONS

- All installation and operation must follow federal, provincial, state, and local codes for wire plumbing, and installing a chimney.
- All work must be performed by qualified personnel only.
- Read and understand all precautions before operating the furnace.
- The furnace is not to be used as a standalone unit. It is recommended that a backup system be in place.
- Retain this manual for as long as you own your Crown Royal Stove. Carefully read and follow these directions.
- Regularly read over this manual to keep you informed.

DANGER!!! Do not start fire with chemicals, volatile fluids, rubber, plastics or garbage. Some processed wood can contain resins and should be avoided. Only competent persons with a sound understanding of this heating method should operate this furnace. Improper firing could result in personal injury and/or damage to unit, and void warranty. Do not burn garbage, gasoline, drain oil, naphtha, engine oil, railroad ties, particle board, leaves, cardboard, or any other flammable liquids.

WARNINGS!!

- All installations and operations of your furnace must follow STATE, PROVINCIAL and LOCAL LAWS pertaining to operations, wiring, plumbing, and building codes. The installation must be performed by a qualified installer.
- Only burn wood in this unit. (Check with provincial, state and local regulations that obtain to banned fuels in designated locations.)
- Only use wood with 20% or less moisture content.
- Do not install this unit on a combustible surface.
- All models operate at atmospheric pressure. DO NOT obstruct, block or plug the overflow vent tube in any way, which is located on top of the furnace.
- This unit cannot be hooked to a chimney that is already serving another appliance. When installing a chimney that is higher than twelve feet, guidelines must be used.
- This unit must never be pressurized.
- Do not use an automatic stoker with this unit.
- Risk of fire: Do not operate with fuel loading heat exchanger door or secondary combustion door open.
- Do not store fuel or other combustible materials within marked installation clearances.
- Inspect, clean flues and chimney regularly.
- All cover plates, enclosures, and guards must be always maintained in place, except during maintenance and servicing.

CAUTIONS!!!

- Hot Surfaces: Keep children away. Do not touch during operation.
- Do not start or operate furnace without checking heating fluid.
- Check for buried cables and utility lines before digging trench.
- For safety and proper temperature control, keep fuel door closed tightly during operation.
- Do not fire up furnace until filled with water.
- Do not start the unit during a prolonged power failure
- Load fuel carefully to avoid injury to hands, fingers and other body parts that may come in contact with the unit's loading door opening.
- Cleaning of the heat exchanger, flue pipe, chimney and combustion motor if used, is especially important at the end of the heating season to minimize corrosion during the summer months caused by accumulated ash.
- Do not open secondary combustion door while in operation. Doing so will result in fire hazard and/or severe burns.
- Always check for adequate water levels.

Please read and follow these precautionary labels that are also found on the outdoor furnace.

!! CAUTION!!



HOT SURFACES
KEEP CHILDREN AWAY.
DO NOT TOUCH DURING OPERATION.
MAXIMUM DRAFT MARKED ON NAMEPLATE.

!! ATTENTION !!



SURFACES CHAUDES
TENIR LES ENFANTS À L'ÉCART.
NE PAS TOUCHER DURANT LE FONCTIONNEMENT.
TIRANT D'AIR MAXIMUM MARQUÉ SUR PLAQUE SIGNALÉTIQUE.

!! DANGER !!



RISK OF FIRE OR EXPLOSION - DO NOT BURN GARBAGE, GASOLINE, DRAIN OIL OR OTHER FLAMMABLE LIQUIDS

!! DANGER !!



RISQUE D'INCENDIE OU D'EXPLOSION - NE BRÛLEZ PAS DE DÉCHETS, D'ESSENCE, D'HUILE DE VIDANGE OU D'AUTRES LIQUIDES INFLAMMABLES.

!! CAUTION !!



TO AVOID ELECTRICAL SHOCK, SWITCH OFF POWER TO UNIT BEFORE REMOVING THIS DOOR

!! MISE EN GARDE !!



POUR ÉVITER TOUT CHOC ÉLECTRIQUE, COUPER LE COURANT VERS L'UNITÉ AVANT DE LA RETIRER

UTILISER UNIQUEMENT DES RACCORDS EN LAITON OU EN ACIER INOXYDABLE SUR LE POÊLE, SINON LA GARANTIE SERA ANNULÉE

USE ONLY BRASS OR STAINLESS STEEL FITTINGS ON STOVE OR WARRANTY IS VOIDED

ATTACH FEED LINE

FIXER LA CONDUITE D'ALIMENTATION

ATTACH RETURN LINE

FIXER LA CONDUITE DE RETOUR

WARNING

BEFORE OPENING HEAT EXCHANGER DOOR, THE LIGHT/FAN SWITCH LOCATED ON THE CONTROL PANEL MUST BE TURNED OFF. FAN MUST BE COMPLETELY STOPPED BEFORE OPENING DOOR. HEAT EXCHANGER DOOR IS EQUIPPED WITH A FAN HOUSING AND WHEEL ASSEMBLY. NEVER PLACE HANDS OR OBJECTS IN THE FAN HOUSING OR PERSONAL INJURY MAY RESULT. HEAT EXCHANGER CLEAN-OUT AREA WILL BE VERY HOT. ALWAYS USE HEAT PROTECTED GLOVES WHEN REMOVING HEATSHIELD, TURBULATORS AND CLEANING HEAT EXCHANGER TUBES OR PERSONAL INJURY MAY RESULT.

AVERTISSEMENT

AVANT D'OUVRIR LA PORTE DE L'ÉCHANGEUR DE CHALEUR, LE COMMANDEUR DE LA LUMIÈRE/OU VENTILATEUR SITUÉ SUR LE PANNEAU DE COMMANDE DOIT ÊTRE ÉTEINT. LE VENTILATEUR DOIT ÊTRE COMPLÈTEMENT ARRÊTÉ AVANT D'OUVRIR LA PORTE. LA PORTE DE L'ÉCHANGEUR DE CHALEUR EST MUNIT D'UN BÔTIER DE VENTILATEUR ET D'UN MONTAGE DE ROUE. N'INSÉREZ JAMAIS LES MAINS OU LES OBJETS DANS LE BÔTIER DU VENTILATEUR, CAR CELA RISQUE DE CAUSER DES BLESSURES. LA ZONE DE RAMONAGE DE L'ÉCHANGEUR DE CHALEUR SERA TRÈS CHAUDE. TOUJOURS PORTER DES GANTS DE PROTECTION CONTRE LA CHALEUR LORS DU RETRAIT DE L'ÉCRAN THERMIQUE, DES TURBULATEURS ET DU NETTOYAGE DES TUBES DE L'ÉCHANGEUR DE CHALEUR, CAR CELA POURRAIT CAUSER DES BLESSURES.

AVERTISSEMENT

LA PORTE DE RAMONAGE DE COMBUSTION SECONDAIRE ARRIÈRE DOIT ÊTRE CORRECTEMENT SCÉLÉE AVANT L'UTILISATION POUR ÉVITER D'ENDOMMAGER LE POÊLE ET D'ANNULER LA GARANTIE

WARNING

REAR SECONDARY COMBUSTION CLEAN-OUT DOOR MUST BE PROPERLY SEALED AND CLOSED BEFORE USE OR DAMAGE WILL RESULT TO FURNACE AND WARRANTY WILL BE VOIDED



DO NOT BURN GARBAGE, GASOLINE, FUEL OILS, OR OTHER FLAMMABLE LIQUIDS OR MATERIALS



NE BRÛLEZ PAS DE DÉCHETS, D'ESSENCE, DE MAZOUT OU D'AUTRES LIQUIDES OU MATÉRIAUX INFLAMMABLES.



INSPECT AND CLEAN FLUES AND CHIMNEY REGULARLY



INSPECTEZ ET NETTOYEZ RÉGULIÈREMENT LES CONDUITS DE FUMÉE ET LA CHEMINÉE.

NE PAS FAIRE FONCTIONNER AVEC LES PORTES DE CHARGEMENT DE CARBURANT OU DE RETRAIT DES CENDRES OUVERTES.

!! CAUTION !!

SECONDARY BURN CHAMBER CONTAINS HIGH LEVELS OF HEAT. NEVER OPEN FURNACE IS IN OPERATION OR PERSONAL INJURY MAY RESULT.

!! MISE EN GARDE!!

LA CHAMBRE DE COMBUSTION SECONDAIRE CONTIENT DES NIVEAUX ÉLEVÉS DE CHALEUR. NE JAMAIS OUVRIR LA PORTE PENDANT QUE LE POÊLE FONCTIONNE, CAR CELA POURRAIT CAUSER DES BLESSURES.

DO NOT STORE FUEL OR OTHER COMBUSTIBLE MATERIAL WITHIN MARKED INSTALLATION CLEARANCES

NE STOCKEZ PAS DE CARBURANT OU D'AUTRES MATÉRIAUX COMBUSTIBLES DANS LES DÉGAGEMENTS D'INSTALLATION MARQUÉS.

DO NOT OPERATE WITH FUEL LOADING OR ASH REMOVAL DOORS OPEN

ALL INSTALLATIONS AND OPERATIONS MUST FOLLOW FEDERAL, PROVINCIAL, STATE, AND LOCAL CODES FOR WIRING, PLUMBING AND INSTALLING THE CHIMNEY. ALL WORK MUST BE PERFORMED BY QUALIFIED PERSONNEL ONLY.

Location

When choosing the location of your furnace you should consider: prevailing wind direction, distance from home for refueling and storage, and give consideration for any effect on your neighbors. Check with your homeowner’s insurance company to ensure they will approve the location relative to the distance from building and combustibles. We recommend a minimum of 25 feet from any building.

Minimum Clearances to Combustibles

Sides	Front	Back	Top	Chimney Connections
36 Inches	60 Inches	36 Inches	12 Inches	60 Inches

Adhere to minimal clearances to combustibles stated in manual and accordance with local, state, provincial, and federal building, and fire codes.

Prior to installation, contact your insurance provider to ensure that installation is in compliance to regulations and all terms have been met.

Storage of your solid fuel must be in a debris free, dry environment that is at least sixty (60) inches from the front of the stove and thirty-six (36) inches from the sides or back of the stove.

WARNING!!! Do not store fuel or other combustible materials within marked installation clearances.

When installing a furnace in a building, outside combustion air is needed. To prevent negative pressure, ensure that there is an adequate source of fresh air to offset the demand of the furnace and other appliances that will draw air from the area they are located. Follow the steps below to prevent negative pressure:

1. Determine the volume of space in the area. This can be calculated by Length (FT) x Width (FT) x Hight (FT) = Volume (CF)
*Include all open areas not closed off by doors.
2. Determine the air input needs for all servicing appliances then add them together and rounding result to the nearest 1000 BTU per hour.
3. Divide the total volume by the total air input requirements and determine if you have a “Confined” or “Unconfined” area with the following results:
 - a. Results of equal to or greater then 50CF/1000 BTU per Hour: “Unconfined”
 - b. Results of less than 50CF/1000 BTU per Hour “Confined”

With results of “Confined” space additional source of air is required. On some installations of “Unconfined” spaces where building has unusually tight construction it might be necessary for additional source of air to also be required

Ground Rod Installation

A properly installed ground rod safe guard electrical equipment and prevent electrolysis in your outdoor furnace. Electrolysis is the decomposition of water into oxygen and hydrogen gasses when an electric current passes through the water. Free oxygen in the water tank will promote rust and over time cause leaks and furnace failure.

Installing a ground rod and connecting to furnace:

1. Near the furnace leg, drive 8’ grounding rod into the ground until it is close to the surface.
2. Install a grounding terminal on the closest stove leg to the grounding rod with self-tapping screws.
3. Secure a ground rod clamp to the grounding rod.
4. Run a ground wire between these two terminals and secure the wire.

Foundation: Blocks or Concrete Pad

Inspect the ground conditions that you intend to install your furnace on. If the area is unstable or has a history of staying wet, you may have to improve the soil with gravel as well as raising the elevation. A cement pad of 4” – 6” inches should then be used. The furnace in most cases can be placed on four cement blocks and they should not be less than 24 inches wide, 24 inches long, 3 inches thick. Obtain the footprint of the model of furnace you have purchased. Place your blocks so that the legs will be in the center of them.

For a pad, the width need not be greater than the outside width of furnace. The length of pad should be as long as the outside length dimension and an added length is desirable as a work area at the loading door. A four-foot extension is most commonly used.

WARNING!!! Do not install this unit on a combustible surface.

MINIMUM CONCRETE PAD SIZE

Place rear stove legs 2” from the back edge of concrete this will allow a 12” overhang for your underground lines to come up.

Model	7200E	7300E	7400E
Length X Width	92” x 54”	100” X 61”	108” x 65”

FURNACE FLOOR PLANS

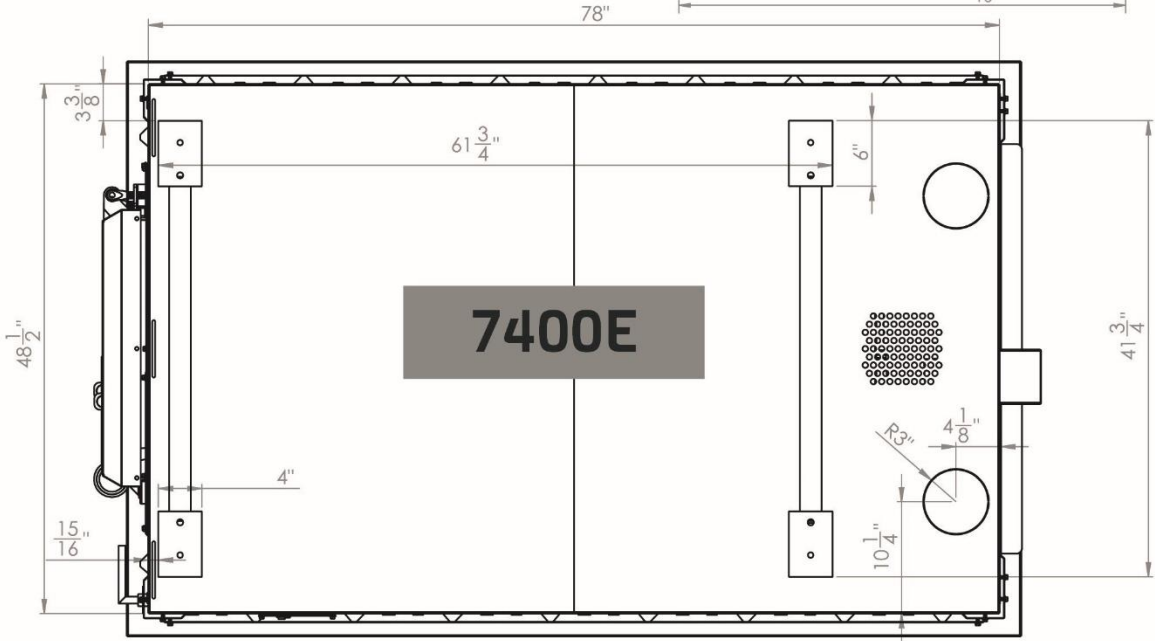
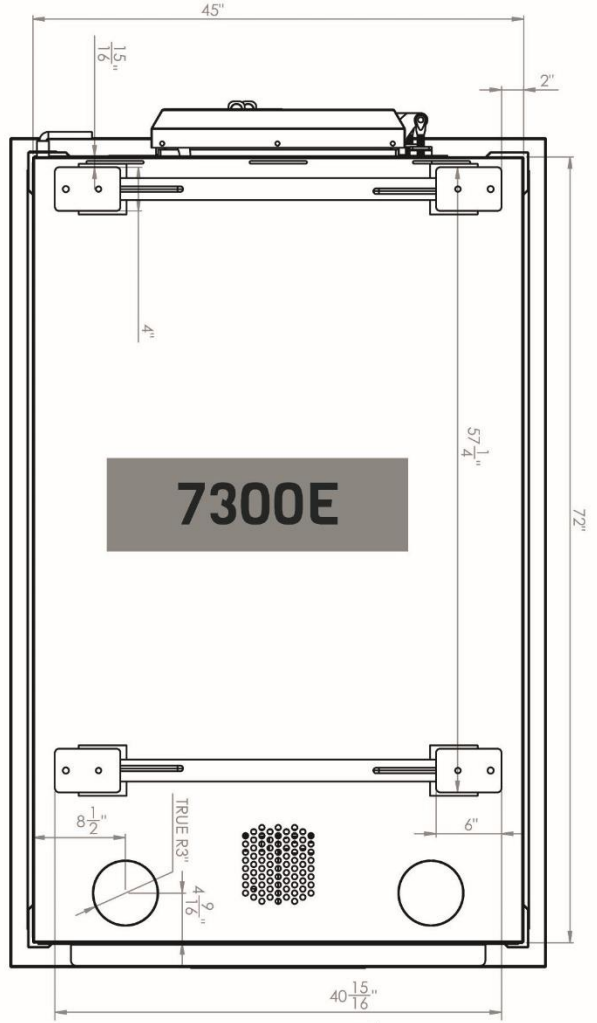
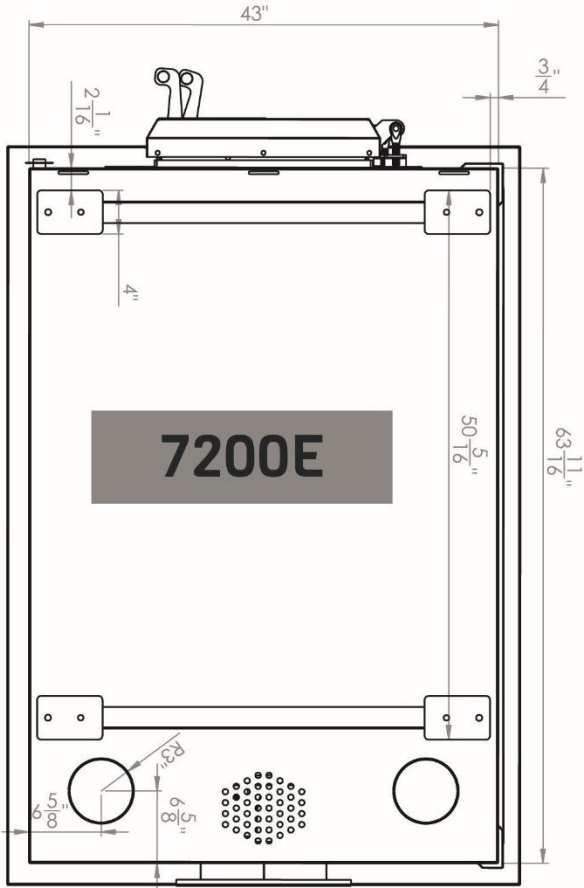

CHIMNEY REQUIREMENTS

ALL INSTALLATIONS AND OPERATIONS MUST FOLLOW FEDERAL, PROVINCIAL, STATE, AND LOCAL CODES FOR WIRING, PLUMBING AND INSTALLING THE CHIMNEY. ALL WORK MUST BE PERFORMED BY QUALIFIED PERSONNEL ONLY.

Chimneys

The size and height all depends on the unit you have purchased and where the unit will be located. Contact your local dealer or Greentech Manufacturing, Inc. for chimney purchase information.

- Adhere by local building codes and the National Fire Protection Association Rules No's 31,54 and 211.
- It is required to use Selkirk Chimney Systems; brand type is UT (Ultra Temp or Galva Temp)
- Selkirk Chimney Systems is a double insulated, stainless steel, Class A Chimney Systems that meets the requirements of UL103 and ULC-S629 and complies with the Chapter 11 of NFPA 211, Standard for Chimneys, Fireplaces, Vents and Solid Fuel Burning Appliances.
- Chimney termination caps are required; installation of spark arresters may be needed in high fire risk areas.
- Selkirk chimneys come in various lengths, spanning from eighteen (18) inches to forty-eight (48) inches. Install each section of piping by placing male and female sections together then twisting them to lock sections together. When installing your chimney piping, it is recommended by many chimney suppliers to brace every eight feet. Also recommended by the chimney manufacturer, that the height of the piping does not exceed a total of forty 40 ft.

WARNING!!! This unit cannot be hooked to a chimney already serving another appliance.

- When installing chimney, please refer to manufacturer's recommendations and requirements for adequate clearances.
- Furnaces come standard with the Selkirk brand anchor plate as well as an 12" chimney length.
- Additional Chimney components and lengths are available from your local dealer or can be purchased direct from Greentech Manufacturing Inc. (Toll Free 866-361-7355)
- Do not attempt to fabricate your own adapters.
- Do not mix Selkirk Chimney with other manufactured brands.
- Do not use existing chimney that already connects to another appliance.
- A major cause of chimney-related fires is failure to maintain required clearances (air spaces) to combustible material. It is of the utmost importance that the chimney be installed only in accordance with the manufacturers stated instructions. These instructions must be reviewed prior to installation of venting components.
- Inspections of chimneys need to be performed at least annually to ensure of any obstructions due to creosote buildup. When necessary, perform cleaning of chimney to prevent chimney fires.

WARNING!!! Risk of Fire: Do not operate with fuel loading door, heat exchanger door or secondary combustion door and/or ash removal doors open. Do not store fuel or other combustible materials within marked installation clearances. Inspect and clean flues and chimney regularly.

ALL INSTALLATIONS AND OPERATIONS MUST FOLLOW FEDERAL, PROVINCIAL, STATE, AND LOCAL CODES FOR WIRING, PLUMBING AND INSTALLING THE CHIMNEY. ALL WORK MUST BE PERFORMED BY QUALIFIED PERSONNEL ONLY.

Underground insulated pipe is a crucial part of your installation. It is designed to transfer hot water from your furnace to your home, garage or shop. Selecting the correct underground pipe depends on several factors such as climate and distance. Choosing a pipe with the least possible heat loss is the most effective way to ensure your furnaces efficiency.

- **Ridged Insulated Underground Tubing** - Ridged insulated pipe manufactured with the highest possible R value ratings.
- **Foam Filled Insulated Underground Tubing** – Designed to respond to intensive environments and climates. Insulated with high quality closed cell polyolefin or polyethylene foam and shelled in a virgin plastic corrugated tile.

Make sure your insulated underground tubing is equipped with at least one supply and one return pipe. This pipe should be at least one inch inside dimension; which is rated at 180 degrees F and 100 PSI continuous flow.

Insulated underground tubing must be without any splices, couplings and joints. Both tubing and piping inside should be one continuous run. Underground insulated tubing needs to be free of damages or punctures that would allow ground water or soil to come in contact with inside insulation and piping. Allowing such contact will cause moisture to seep through the insulated pipe and result in extreme heat loss. Insulated underground tubing must remain watertight or will be required to be replaced.

Installation Requirements:

- The trench must be 24" deep and 8"–12" wide. If possible, have a gradual slope in your trench to allow drainage away from lines and out of the trench bottom. Place electrical supply in bottom of trench and cover with 6" of gravel or dirt. At this point a water barrier is required. Several methods are possible, but the most important factor is; if ground water comes in contact with your heating lines, it will be the greatest heat loss to your system. A minimum of R10 insulation value is recommended, and a water-tight vapor barrier such as a continuous poly tube of plastic PVC pipe to encase your insulation is a must. NOTE: If you need to bury lines under an area where vehicles will cross, you should increase the depth of the trench to three feet or place planks over the trench in that area to spread the load and reduce the pressure generated on the lines.
- All wiring must conform to local codes. Use an electrical wire rated and approved for underground installations. This wiring can be placed in the same trench below the water lines. Use 12-2 UF wire with ground to provide power to the combustion blower, aquastat, night light, etc. at the furnace. This is satisfactory for most applications, but a state certified electrician must be consulted.
- The supply & return tubing and the power wire can be lowered in the trench, then brought through the buildings being heated, and extended a minimum of 36" out of the soil where the furnace is to be placed. Seal the openings around the tubing where it enters the building. Also Seal the tubing where it extends out of the ground at the location where the furnace is to be placed.
- Connections to the furnace are clearly marked. The installation of isolation valves at both ends of the pump is recommended as well as a valve at the return line. This will allow you to shut off the water supply for repair or if additional heating components are added to the system. It is recommended that piping used is able to withstand 100 PSI at 180 F, and is at least 1" (inch) in diameter. 1 ¼" (inch) piping is recommended for larger systems. A single junction box at the rear of the furnace is included for your power supply and should be connected by a qualified person.
- A hole large enough to accommodate two lines and insulation is required and attention to sealing this point of entry is very important. Be sure to bring pipes, insulation and vapor barrier completely through the wall and seal from both sides.

ALL INSTALLATIONS AND OPERATIONS MUST FOLLOW FEDERAL, PROVINCIAL, STATE, AND LOCAL CODES FOR WIRING, PLUMBING AND INSTALLING THE CHIMNEY. ALL WORK MUST BE PERFORMED BY QUALIFIED PERSONNEL ONLY.

Making Water and Electrical Connections at the Furnace

- After the furnace has been placed on the concrete or pads, remove the panel at the back of the stove.
- The return (cold water) pipe must be connected to the fitting at the upper position and the supply (hot water) at the fitting toward the bottom of the furnace. If multi-pole locations are to be heated, tees must be added on both the supply (hot) and return (cold). It is necessary to use **brass fittings** between the stainless and other metals.
- The furnace has been pre-wired at the factory; therefore, it is only necessary to connect the common from the wire from the trench to the common from the stove, neutral to neutral, ground to ground. Ensure that the connections are watertight.
- Return the panel to the back of the stove.

Piping Inside the Building

It is recommended that piping used is able to withstand 100 PSI at 180 F, and is at least 1" (inch) in diameter. 1 ¼" (inch) piping is recommended for larger systems.

- For each building, a circulation pump is needed. The pump can be located on the supply side (hot water).
- Before each pump, a filtering device must be installed. This filter will minimize the contaminants in the water and maximize the life of the circulation pump.
- If the central heating system in the building is a forced air furnace, it is important to select the appropriate water to air exchanger. Contact your heating contractor for proper size. The coil is to be installed in the furnace plenum. If there is an air conditioning evaporator coil in the plenum, install the water to air coil after the a/c coil.
- If the central heating system is a hot water boiler system, a water to water heat exchanger is needed. The water from an open system will contaminate the closed system if the waters are mixed together.
- It is advisable to install ball valves, isolation flanges, etc. to make the removal and the replacement components easier.

Wiring Inside the Building

- The electrical wiring must be done by a licensed electrician to ensure the system will operate as desired and is safe.
- It is recommended that the circulation pump or pumps run continuously.
- The existing forced air circulation blower needs to be wired through the circuit board to a 24 volt wall thermostat which is dedicated for this purpose. The other wall thermostat which is for the forced air (Oil, LP, NG or Electric) is left intact. The new 24 volt wall thermostat will cause the circulation blower to run without the burners coming on. A licensed electrician needs to perform the wiring.
- The electrical for a boiler system is more complicated because the existing boiler wall thermostat is used but the burners on the (Oil, LP, NG or Electric) boiler are not to operate when the water from the furnace is to provide heat. It is necessary to have a licensed electrician wire this configuration.
- If air conditioning is used, you must add a relay DPDT to prevent the condenser from turning on when the fan is energized.

Electrical Requirements

Electrical Rating: 120 AV Volts, 6 AMPS, 60 Hz. Wire must be rated and approved for direct burial if it is to be buried in the same trench as the water lines. Boiler power connection box is located at rear of boiler inside back cover. Minimum supply 15 AMPS. Maximum device 15 or 20 AMPS. **USE COPPER CONDUCTORS ONLY.**

EXISTING HOT WATER HEAT - INSTALLATION

ALL INSTALLATIONS AND OPERATIONS MUST FOLLOW FEDERAL, PROVINCIAL, STATE, AND LOCAL CODES FOR WIRING, PLUMBING AND INSTALLING THE CHIMNEY. ALL WORK MUST BE PERFORMED BY QUALIFIED PERSONNEL ONLY.

It is recommended that piping used is able to withstand 100 PSI at 180 F, and is at least 1" (inch) in diameter. 1 ¼" (inch) piping is recommended for larger systems.

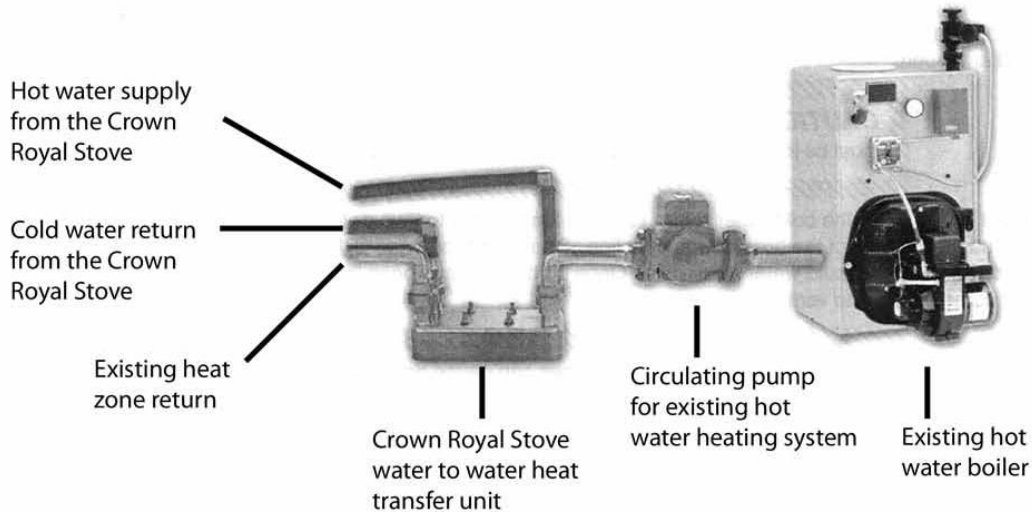

The Crown Royal Stove shall be installed without interfering with normal delivery of heated water from the original boiler.

The Crown Royal Stove shall be installed without affecting the operation of the electrical and mechanical safety controls of the original boiler.

The Crown Royal Stove shall provide a changeover from one fuel to the other without requiring manual adjustment of any controls or components other than the thermostats.

The Crown Royal Stove shall have provisions for preventing, of adequate water capacity within the boiler to prevent damage from loss of circulation due to electrical power failure.

The Crown Royal Stove shall be installed without changing the function of the controls or rewiring the original boiler. A wiring interconnection is permitted. The electrical system of both boilers shall be powered from a single branch circuit without exception.

FOR UNITS USED IN CANADA THE FOLLOWING IS RECOMMENDED:

- Operate the existing boiler periodically to ensure that it will operate satisfactorily when needed.
- Do not relocate or bypass any of the safety controls in the existing boiler installation.
- The operation of the existing gas boiler must be verified for acceptable operation before and after installation of the Crown Royal Stove by a gas fitter who is recognized by the regulatory authority.
- Do not connect to any chimney or vent serving a gas appliance.
- Ensure the installation complies with the requirements of CAN/SCA-B365. Any changes to the installation should comply with CSA B139 (for oil-fire), C22.1 (for electric), or CAN/CGA-B149.1 or CAN/CGA-B149.2 (for gas-fired).

DOMESTIC HOT WATER & FORCED AIR - INSTALLATION

ALL INSTALLATIONS AND OPERATIONS MUST FOLLOW FEDERAL, PROVINCIAL, STATE, AND LOCAL CODES FOR WIRING, PLUMBING AND INSTALLING THE CHIMNEY. ALL WORK MUST BE PERFORMED BY QUALIFIED PERSONNEL ONLY.

DOMESTIC HOT WATER

The domestic hot water flat plate kit consists of a water to water heat transfer unit and the fittings needed to hook it up. The unit goes on top of the domestic hot water heater and is connected as shown below.

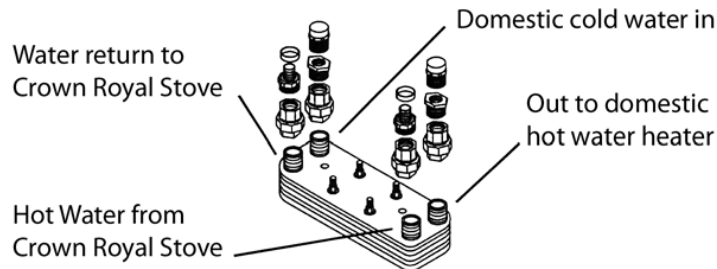

EXISTING FORCED AIR

A water to air heat exchanger is inserted in the existing plenum. In most cases the heat exchanger is placed in a horizontal position, keeping all four sides level. The air must be forced through the finned area of the heat exchanger evenly. The hot water line coming from the hot-water tube enters the bottom fitting of the heat exchanger and exits the top fitting, which returns to the furnace. If the plenum is too large or too small, it must be altered to fit the heat exchanger properly.

After installation of the add-on water to air exchanger, the air flow may need to be increased.

Methods of doing so are:

BELT DRIVE SYSTEM: Blower pulleys and motor pulleys may be changed but the electric current flowing through the motor shall not exceed the nameplate rating. (A blower motor or larger power may be used.)

DIRECT DRIVE SYSTEM: The motor shall not be changed; however, the speed of the motor may be increased.

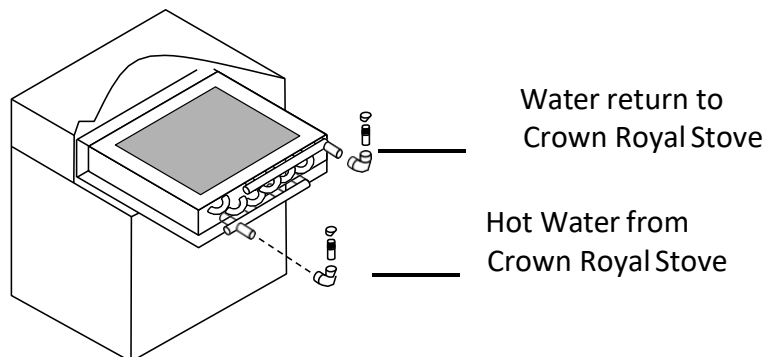

THE HEAT EXCHANGER: Air blows through the heat exchanger's grill taking the heat from the water heated grill and blowing it into your existing ductwork.

CAUTION!!! When installing heat exchangers do not tamper with existing controls. Wiring to existing blower can be done with a line voltage or low voltage thermostat.

NOTE: Wire thermostats according to directions provided by the manufacturer.

Brazed Plate Water to Water Exchanger

The brazed plate heat exchanger can be installed on either the cold side or the hot side of the hot water heater. If installed on the cold side, the hot water needs to be left on to maintain the temperature in the hot water heater. If installed on the hot side, the hot water heater needs to be turned off and the hot water heater is now a reservoir.

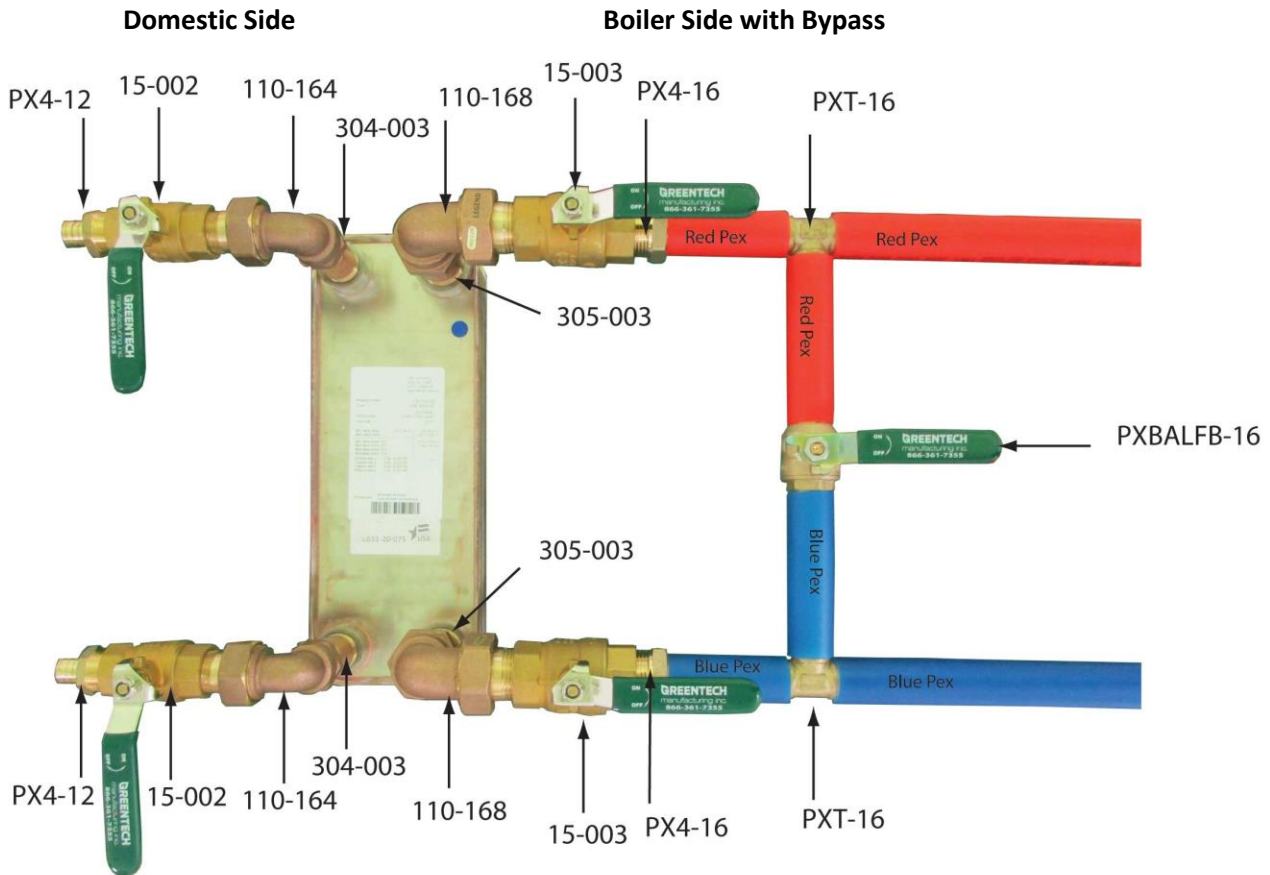

PART NUMBER	DESCRIPTION
PX4-12NL	3/4" PEX X MALE ADAPTER (NO LEAD)
15-002	3/4" BALL VALVE (NO LEAD) FIP X FIP
110-164	3/4" UNION ELBOW IPS
304-003	3/4" X 2-1/2" RED BRASS NIPPLE
110-168	1" UNION ELBOW IPS
305-003	1" X 2-1/2" RED BRASS NIPPLE
15-003	1" BALL VALVE (NO LEAD) FIP X FIP
PX4-16 NL	1" PEX X MALE ADAPTER (NO LEAD)
PXT-16 NL	1" PEX X 1" PEX X 1" PEX TEE (NO LEAD)
PXBAL-16 NL	1" PEX X 1" PEX BALL VALVE (NO LEAD)

WATER TO AIR SETUP - INSTALLATION

Water to Air Heat Exchangers are for use in your hot air plenum of your existing forced air furnace, to transfer heat into your existing forced air system.

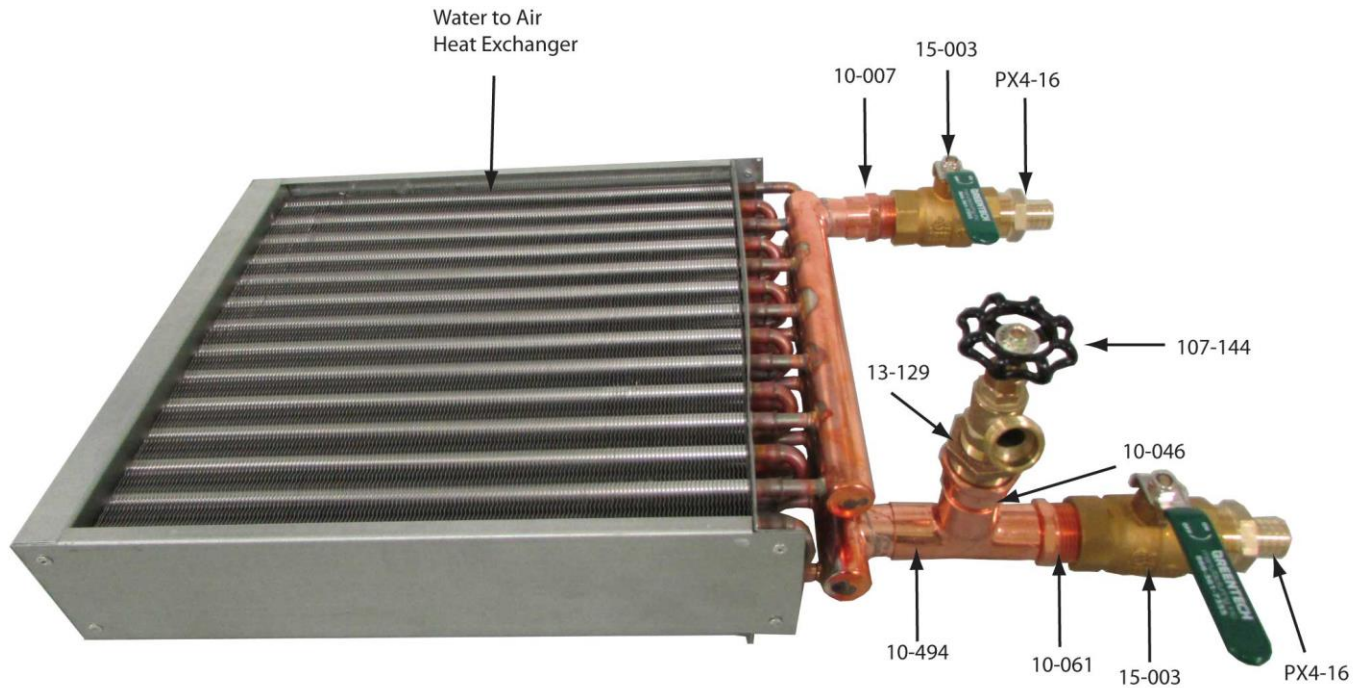

PART NUMBER	DESCRIPTION
10-007	1-1/4" COPPER ADAPTER C X FEMALE
15-003	1" BALL VALVE FIP X FIP
PX4-16	1" PEX X MALE ADAPTER
107-144	3/4" MALE BOILER DRAIN MNPT
13-129	1" X 3/4" BRASS HEX BUSHING
10-046	1" COPPER FITTING ADAPTER FTG X FEMALE
10-494	1" X 1" X 1" COPPER TEE
10-061	1" COPPER ADAPTER FTG X MALE
15-003	1" BALL VALVE FIP X FIP

STOVE COMPONENTS



	Description	Part Number
A	Auto Reset Snap Disk	50-035
B	Electronic Temperature Control	50-051
C	Solenoid	50-036
D	On-Off-On Switch	50-030
E	Thermowell	50-038
F	Fiberglass Silicone Door Rope – 1”	50-051
G	High Temp Silicone	50-050
H	Combustion Motor – 7300E & 7400E	50-020
I	Combustion Motor – 7200E	50-021
J	Ash Rake	60-007
K	Water Level Indicator	60-019
L	Red Push Button Switch	50-104
M	Encapsulated Timer Relay	50-105
N	Control Chemical & Test Bottles – 1 Gallon	Control Chemical

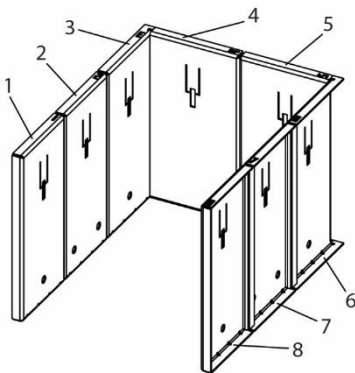

O	Air Panels:	7200E	7300E	7400E
#1	Front Side Left Air Panel	CRP1209	CRP1419	CRP1613
#2	Middle Side Left Air Panel	CRP1210	CRP1420	CRP1614
#3	Rear Side Left Air Panel	CRP1211	CRP1421	CRP1615
#4	Rear Left Air Panel	CRP1212	CRP1422	CRP1616
#5	Rear Right Air Panel	CRP1213	CRP1423	CRP1617
#6	Rear Side Right Air Panel	CRP1214	CRP1424	CRP1618
#7	Middle Side Right Air Panel	CRP1215	CRP1425	CRP1619
#8	Front Side Right Front Air Panel	CRP1216	CRP1426	CRP1620

Pristine Firebrick Refractory Part Numbers for All Models

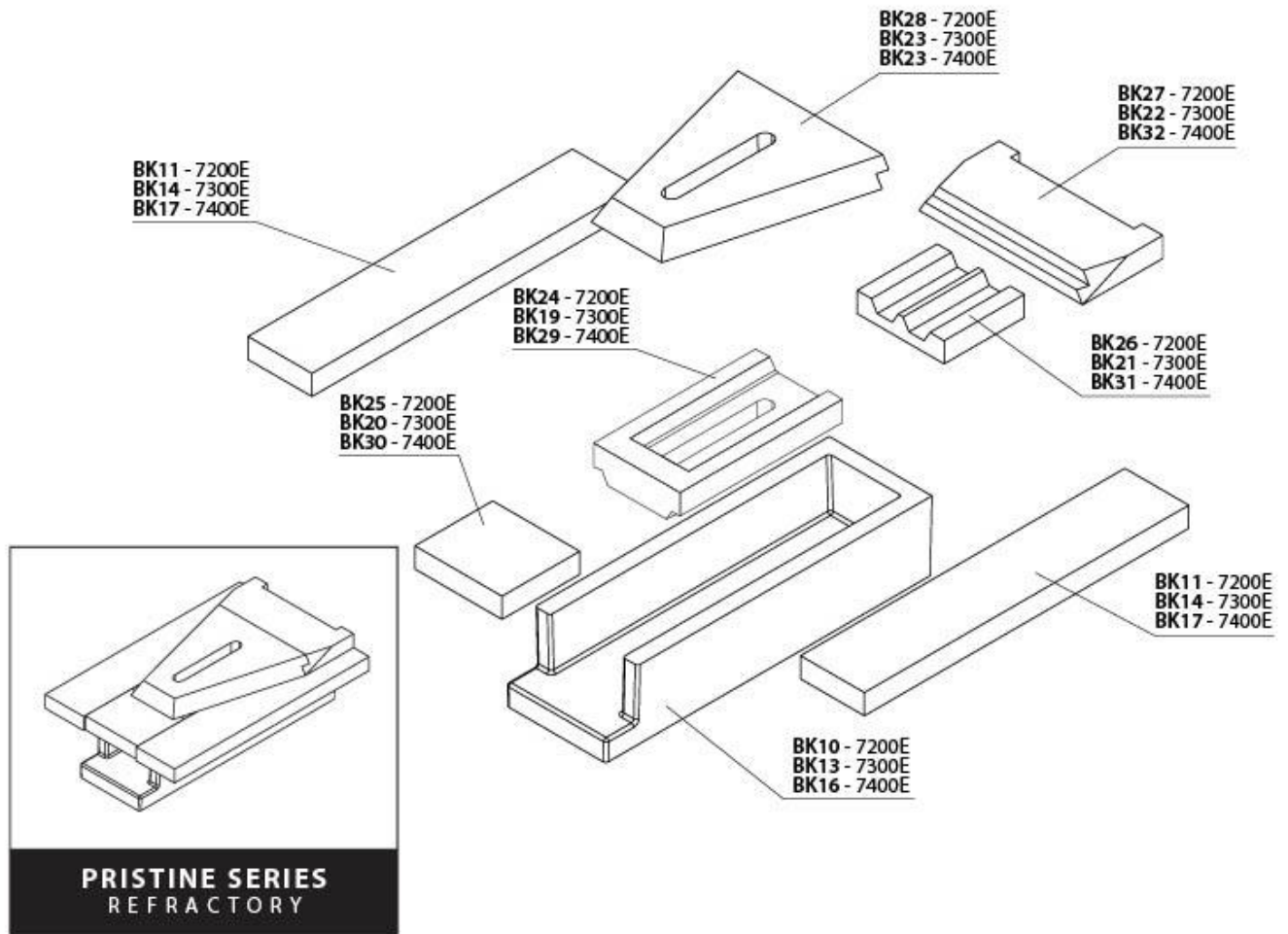

CONTROL PANEL

The aquastat powers the combustion blower to maintain the desired water temperature. The aquastat is set at 180°F at the factory, which means that combustion blower will run until the water in the jacket reaches 180°F. Only qualified personnel should be adjusting the temperature controls.

When filling the firebox place the fan/light switch to light off position and press the red load switch time delay button. Wait 20 seconds to allow the smoke to evacuate from the furnace before opening the firebox door. For night filling the fan/light switch can be in the light position while filling which will turn on the light above the firebox door.

Caution – Never open the firebox door before pushing load switch time delay and waiting 20 seconds for smoke to evacuate from furnace before opening firebox door. Damage to furnace and personal injury may result.

AQUASTAT

Controls the water temperature inside the water jacket. Factory set at 180°F with 10° differentials.

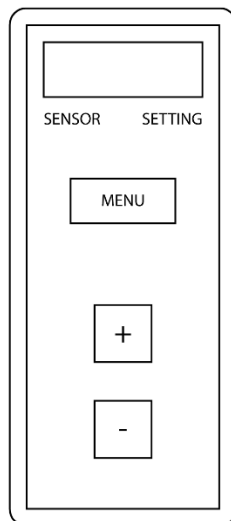

LOAD SWITCH
TIME DELAY

WHEN LOADING FURNACE WITH FUEL,
PUSH LOAD SWITCH AND WAIT 20
SECONDS TO ALLOW SMOKE TO
EVACUATE FROM FURNACE BEFORE
OPENING FIREBOX DOOR.

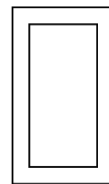

LIGHT
OFF
FAN

ANNUAL WATER TESTING IS REQUIRED
TO MAINTAIN WARRANTY. REFERENCE
OWNERS MANUAL FOR DETAILS.

!! CAUTION !!

TO AVOID ELECTRICAL SHOCK, DISCONNECT POWER UNIT BEFORE REMOVING THIS PANEL.
DO NOT OPEN FIREBOX DOOR BEFORE PUSHING LOAD SWITCH - TIME DELAY,
AND WAITING 20 SECONDS FOR SMOKE TO EVACUATE FROM FURNACE.
DAMAGE TO FURNACE AND PERSONAL MAY RESULT.

LOAD SWITCH

Turns the combustion blower on to allow smoke to evacuate from furnace for 100 seconds, then returns to normal operation.

FAN/LIGHT SWITCH

Controls both fan and light. Ensure switch is in the light position before opening fuel door. This shuts the fan off and turns on light. Always put the switch in the fan position after refueling.

FILLING THE WATER JACKET

Your outdoor furnace has a vent pipe that protrudes through the roof and is located in front of the lift hook. By placing a garden hose in this pipe you can fill your furnace to the proper water level. Because this furnace is an open-to-atmosphere system, it is normal that water will have to be added annually. Depending on circumstances, 5 or 10 gallons is not unusual. To make this procedure more convenient, a boiler drain valve (tap, faucet) can be installed into the return furnace line allowing you to connect a double female (automatic washing machine hose) between it and your domestic supply line.

On your initial filling of your furnace make sure to inspect all connections in your system for leaks. In your system a bleeder valve should have been installed at the highest point. This will allow you to remove any air from the system.

CAUTION, DO NOT FIRE FURNACE UNTIL IT IS FILLED WITH WATER. Allow furnace to run for two days and check water levels and fittings for leaks. If all is okay, you now should add the manufacturer's recommended water treatment.

FIRING THE FURNACE FOR THE FIRST TIME

Pristine Series furnaces are equipped with high temperature refractories. These refractories require curing upon first initial start-up. It is extremely important to heat the firebox up slowly to complete the curing process of the refractories or cracking will result.

Begin by building a fire with kindling-sized pieces of wood, kindling should be no larger than 2" in height by 2" in width by the length of the firebox in depth. Add small pieces of wood (no more than 5 pieces) to minimize temperature spikes. Keep the fire satisfied for the next 4-6 hours. The complete curing process requires attention, be sure to provide adequate time to allow refractories to properly cure.

After the 4-6 hours of kindling fire, add heavier fuel gradually until a suitable fire is achieved. The furnace will continue to feed an air supply to the fire until your aquastat shut off temperature is reached (180F). On this initial start up the water jacket will reach what is called the dew point. This creates sweat inside the firebox which may last a couple of days and is normal. Condensation will come out of all doors until the unit reaches operation temperature. Heating of the water will also cause it to come out of the fill pipe. All are normal occurrences.

Although everyone has different methods of firing, filling your furnace to capacity reduces the efficiency of the furnace. It is better to load twice a day with less wood than once a day filling to capacity. Smaller fuel loads burn hotter, cleaner and more thoroughly. By burning off more of the gases (smoke), which is wood broken down, you enhance the overall efficiency of your system by reducing creosote and increasing heat transfer to the water.

STARTING A WOOD FIRE WITHOUT A COAL BED

1. Check to see if both the rear clean-out doors and the secondary combustion door are closed and secure.
2. Before opening the firebox door, switch the light/fan switch to the fan position located on the control panel.
3. Open the firebox door and insert a few pieces of kindling over the nozzle in the firebox. Place crumpled paper on top of kindling and light. Do not use chemicals or fluids to start the fire.
4. When the kindling wood is well ignited, add larger pieces of wood. Let these pieces start to ignite.
5. Shut the firebox door.
6. When firing the stove, the first time of the season the water jacket will sweat as the fire warms the cold water. This could last for 48 hours and does not indicate the stove is leaking water.
7. Burning wood with a 20 % or higher moisture content will result with noticeable water in the firebox and secondary burn chamber.

DAILY FUELING & FIRING ROUTINE

Prior to opening fuel door, aggressively pull and push heat exchanger cleaning rod six to ten times which will ensure proper drafting. On the control panel located on the left side of the furnace remember to turn fan/light switch to either off or light position. Next press load switch time delay and wait 20 seconds to allow smoke to evacuate from the furnace. Open the fuel door slowly and stand behind the door ensuring the door is between you and the firebox. Failure to wait may cause an injury from a fire flare back.

Always check for adequate water using the water level indicator that is supplied with your stove. This indicator is placed in the fill tube and can be easily checked daily to ensure the proper water level. Based on the temperature of the stove, the water level will fluctuate.

Do not load the firebox more than seventy-five percent (75%) with wood. If additional fuel is added, you will not maintain a hot enough burn and your efficiency rate will deteriorate. Only add enough wood to provide heat until the next fueling time. Overfilling the firebox will cause the fire to smolder, which will create excessive creosote and result in more fuel being consumed.

PROPER DRAFTING

Maintaining a proper draft will ensure the complete process of gasification and will keep your furnace burning efficiently. Make sure all exhaust pathways are free and clear of debris. Remove any accumulated ash in the following areas: heat exchangers, secondary burn chamber, and chimney pipe. Regularly clean the fan wheel and finger guard located in the heat exchanger area. Make sure the fan wheel moves freely. Ensure that exhaust blower and solenoids are in good working order. Check the proper sealing of all furnace doors and replace door gaskets when necessary.

MAINTAINING COMBUSTION

A minimum of a 4" wood coal bed is required at all times to ensure good combustion at the lowest burn rate for which the furnace is warrantied.

SAFETY

Never open the firebox door without pressing the load switch time delay button, and waiting 20 seconds to allow the smoke to evacuate from the furnace. This button is located on the control panel. It is designed to turn on the combustion blower to evacuate all smoke from the unit. Failure to do so could result in damage to the furnace and cause personal injury.

Whenever the firebox door is to be opened, it should always be cracked slightly to allow oxygen to enter and burn off any combustion gases that are present before fully opening. Failure to do this could result in a sudden ignition of the unburned gases when the door is opened.

A stove should never be filled with excess wood so that the flue gas exit is blocked or impeded in any way. Burning wood generates carbon monoxide and if the flue gas exit is blocked the carbon monoxide can be forced into the area the stove is heating and have fatal consequences. If installed indoors a minimum of one carbon monoxide/smoke detector is required to be located in the room where the appliance is installed.

WARNING!!! Risk of Fire: Do not operate with fuel loading and / or secondary combustion doors open. Do not store fuel or other combustible materials within marked installation clearances. Inspect and clean flues and chimney regularly.

CAUTION!!! Hot Surfaces: Keep children away. Do not touch during operation.

STARTING DURING A PROLONGED POWER FAILURE

During a prolonged power failure, where no power is being sent to the furnace, do not load with new fuel or try to start a new fire. It is recommended that you contact your local dealer or Greentech Manufacturing, Inc. to find out what size of generator is needed to keep your furnace running. Once an approved generator is connected to the stove, the unit may be started normally.

CAUTION!!! Do not start the unit during a prolonged power failure.

WEEKLY MAINTENANCE

Weekly cleaning of the secondary combustion areas are extremely important for the complete process of gasification. **Use extreme CAUTION when opening and cleaning doors, these areas will still be hot and could cause personal injury.**

1. Fuel in firebox must be burned down to perform weekly maintenance.
2. Always check for adequate water using water level indicator that is supplied with your stove. This indicator is placed in the fill tube and can be easily checked daily to ensure proper water levels. Never fire the unit until adequate levels of water are satisfied. If unit is low fill immediately.
3. Always make sure light/fan switch on the control panel is in the off position before opening any access doors to perform weekly maintenance.
4. Heat exchanger door is equipped with a fan housing and wheel assembly; fan must be completely stopped before opening heat exchanger cleanout door.

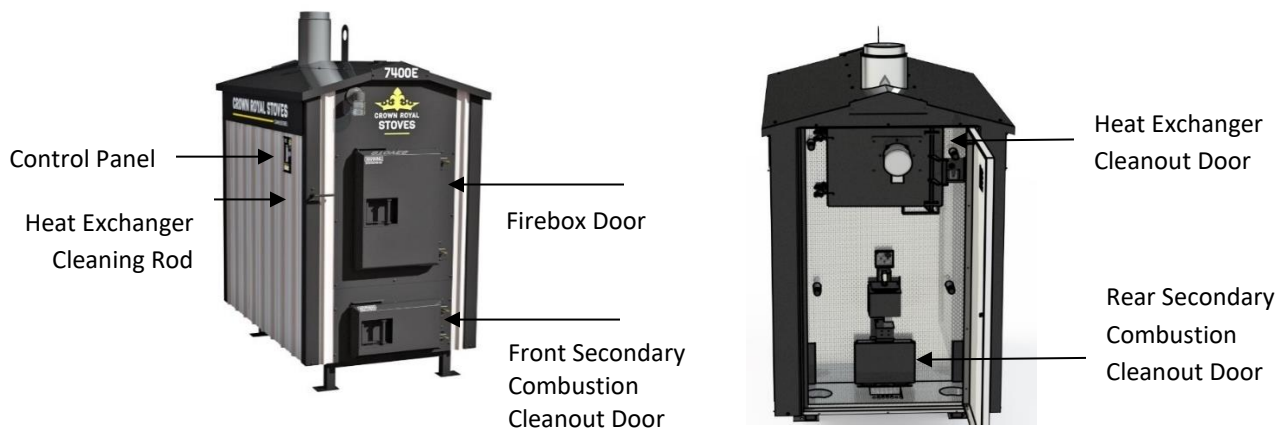

HEAT EXCHANGER AREA CLEANING



Heat exchangers are in the back of the stove and run vertically which can be accessed from the back of the stove. Open the rear access door and open the top heat exchanger cleanout door. Weekly cleaning of the heat exchanger area will prevent the buildup of fly ash that can cause the stove to burn inefficiently. Clean off excess fly ash off the blades of the combustion fan. It is suggested you use an ash vac to ensure proper disposal of fly ash.

CAUTION!! Heat Exchanger door is equipped with a fan housing and wheel assembly. Never place hands or objects in blower assembly or personal injury may result.

WARNING!! Burning wood with a moisture content of 20% or higher will lead to excess creosote buildup on the Heat Exchangers.

SECONDARY BURN CHAMBER CLEANING

An ash rake will also be included with the stove; this will be used to clean the secondary burn chamber area. Stoves are equipped with a front and rear secondary combustion cleanout door. This area should be cleaned after cleaning the heat exchanger tubes. Simply use the rake (included) making a few sweeps through this area, it will prevent buildup of fine ashes. **Use extreme caution while cleaning firebrick.** Store all ash in a fire-retardant closed container that is placed on a non-combustible floor or ground, well away from all combustible materials until final disposal. Ashes should remain in fire-retardant closed container until completely cooled.

Usage of authorized Control chemical is required in all Crown Royal Stoves. To uphold your warranty annual water testing is necessary.

Do not allow moisture to come in contact with ashes the in the firebox. Do not rake coals into the secondary burn chamber. It is mandatory to have a rain cap on the termination of your chimney.

Frequently check for accumulated soot, creosote, and ash build-up until experience shows how often cleaning is necessary.

Check daily for creosote build-up until experience shows how often cleaning is necessary. Be aware that the hotter the fire, the less creosote is deposited. However if the firebox is building up with creosote, then the moisture content within the wood is too high. Weekly cleaning may be necessary in warmer weather, while monthly cleaning may be adequate in the coldest months. Have a clearly understood plan of how to handle a chimney fire. See (RUNAWAY CHIMNEY FIRE)

Daily Maintenance

- Check water level and add as necessary.
- Check for adequate fuel supply.
- Check for ash buildup in the firebox, secondary burn chamber and exchanger tubes. (Use a fire-retardant closed container to empty ashes into).
- Aggressively pull and push the heat exchanger cleaner six to seven times.

Weekly Maintenance

- Perform weekly maintenance to heat exchanger area, and secondary burn chamber areas to ensure proper draft.
- Check fan and solenoid to ensure proper air velocity is happening at ejection points.
- Remove any excess creosote from the firebox door and frame.

Monthly Maintenance

- Check the water level indicator and add water If low, until excess flows from the overflow pipe located in front of the chimney.
- Check chimney and connectors for creosote formation.

Annual Maintenance

- Lubricate solenoid shaft.
- Check combustion motor and solenoid to ensure proper air velocity is happening at ejection points.
- Check the door gasket and replace if needed.
- Clean out any ash buildup from firebox, heat exchanger area, and secondary burn areas.
- Check chimney: remove any creosote, soot or ash build-up that may have occurred.
- At the end of the season, thoroughly clean out all the ashes in the firebox, chimney, heat exchangers and secondary burn areas.
- Make sure chimney cap is in good condition to prevent rain from entering stove.

Remember: Your preventive maintenance program will give you years of trouble free service.

Off Season Maintenance

- At the end of the heating season, shut off the pump, clean the firebox, heat exchangers, and secondary burn chamber.
- Check the water level indicator and refill until the water is full, take a water sample to be sent in for testing, if the water treatment is needed turn on the circulation pump for at least four hours to mix the treatment thoroughly, check for leaks and then shut the pump off.

- Care for the exterior of your furnace is minimal. The unit may be washed using water and a mild non-abrasive cleaner suitable for painted surfaces. Avoid direct water pressure to electrical components and connections.

CAUTION!!! Make certain that all electrical power to the furnace and components are shut off before washing.

REPLACING DOOR ROPE GASKETS



To replace door rope gaskets, start with a 1" putty knife to scrap out old rope gasket; next clean out the gasket channel with wire brush, then fill cavity with high temp silicone 1" wide and ½" thick. Press new rope gasket in cavity making sure to embed rope into the silicone, fill in outside corners with silicone and troll flat with putty knife. Leave door the open for 24 hours.

AIR PANEL REPLACEMENT

Air panels are located inside your firebox. These panels are labeled for easy removal and replacement when needed. To remove apply force to the bottom of the air panel and lift off the hook. Air panels need to be removed in sequential order from front to rear. Air panels are labeled from left to right in numerical order from 1 to 8.

#1 – Side Front Left	#2 – Side Middle Left	#3 – Side Rear Left
#4 – Rear Left	#5 – Rear Right	
#6 – Side Rear Right	#7 – Side Middle Right	#8 – Side Front Right

ASH REMOVAL, ROTATION & DISPOSAL

CAUTION! Ashes should never be allowed to accumulate in secondary burn area and vertical heat exchangers. Ashes in contact with these areas act as an insulator, causing incomplete gasification. With an excessive ash buildup, primary combustion air is restricted, and the unit's output will be reduced. Damages will result to the unit if maintenance is not performed.

When cleaning the ash, place the ashes in a fire-retardant closed container, they then should be placed on a noncombustible floor or on the ground well away from all combustible materials until final disposal. Ashes should remain in the fire-retardant closed container until all cinders have cooled, in an area that is at least sixty (60) inches from the front of the stove and thirty-six (36) inches from the sides or back of the stove.

CAUTION: Hot coals can last for days. Disposing of them improperly or too soon can cause a fire.

WARNING!!! RISK OF FIRE

With the exception of the start-up and ash removal periods, the secondary combustion and loading doors should never be left open. This unit should never be left unattended with any of the doors left open.

CREOSOTE FORMATION & REMOVAL

When wood is burned organic vapors and tar combine with the expelled moisture forming creosote, which clings to the interiors of the stove. Creosote vapors condense in the relatively cool chimney of a slow burning fire; as a result, creosote accumulates on the flue lining. When creosote ignites it creates an extremely hot fire and can cause damage to the stove and /or persons. The chimney and its connectors should be inspected monthly, during the heating season to determine if a buildup is occurring. If creosote has accumulated it should be removed to reduce the risk of a chimney fire.

RUNAWAY CHIMNEY FIRE

To avoid a chimney fire; ensure that daily, weekly, month and annual maintenance techniques are being followed.

If a fire is to occur, close all doors including the firebox and heat exchanger doors, shut down the power to the unit. This will eliminate new oxygen from being introduced into the firing chamber, this will distinguish both chamber and chimney fires.

If the furnace fails to heat up:

1. Check fire.
2. Check combustion motor for operation.
3. Check solenoid damper is open to allow air velocity.
4. Check water level of furnace.
5. Check for creosote blockage at chimney and bypass trough.
6. Check temperature setting.
7. Check for power at furnace.
8. Check heat exchanger tubes and secondary combustion areas for blockage.
9. Check to make sure all doors are properly adjusted.

If furnace water is hot, but buildings do not have heat:

1. Check pumps and check for closed valves.
2. Check filter or Y-Strainer for flow blockage.
3. Check for air in system at exchanger by bleeding off.

If furnace boils:

1. Check that firebox door is closing properly and that the door gasket is completely sealed.
2. Check that the secondary combustion doors are properly closed and the gasket is completely sealed.
3. Check that the solenoid damper plate is opening and closing without hang-ups.
4. Check that the temperature settings and water levels are correct.

If furnace has shut down:

1. Check to ensure that the unit has power (does the outside light work).
2. Check the water temperature (furnace has a high temperature cut-out of 190 degrees °F). Furnace will need to drop 50 Degrees °F before it automatically resets.
3. If all the checks have not corrected the problem, have a qualified technician check the control panel.

Blower will not come on:

1. Check to see if the high limit switches may be shut off because the water temperature is higher than aquastat setting.
2. Wait and allow water to cool down.

Abnormal creosote buildup in chimney and flue:

1. Check the moisture of your wood. Recommended moisture content is 20%.

7200E Electrical Wiring Diagram

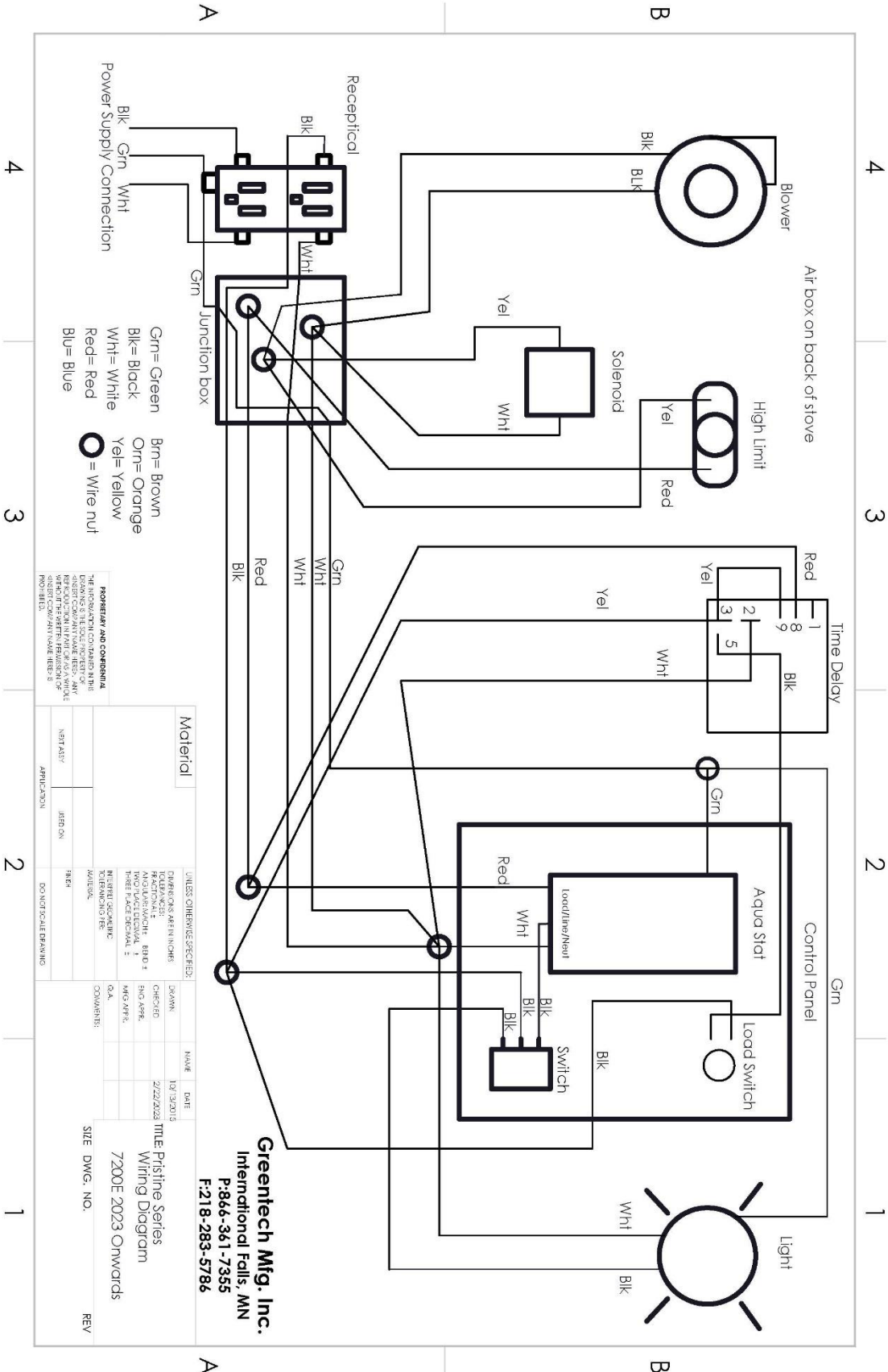

PROMETHEAN AND COMPENSIA
 THE INFORMATION CONTAINED HEREIN IS THE PROPERTY OF PROMETHEAN AND COMPENSIA. ANY REPRODUCTION OR TRANSMISSION OF THIS INFORMATION WITHOUT THE WRITTEN PERMISSION OF PROMETHEAN AND COMPENSIA IS STRICTLY PROHIBITED.

Material	UNLESS OTHERWISE SPECIFIED:	DATE	REV
	DIMENSIONS ARE IN INCHES	10/31/2015	
	FRACCTIONS ARE IN INCHES	CHECKED	
	NO UNUSUAL TOLERANCES	2/22/2023	
	NO UNUSUAL TOLERANCES	ENG APPR.	
	THREE PLACE DECIMALS	ENG APPR.	
	UNLESS OTHERWISE SPECIFIED:	Q.A.	
	USE THE FOLLOWING TOLERANCES UNLESS OTHERWISE SPECIFIED:	COMMENTS	
	MATERIALS		
	FINISHES		
	DO NOT SCALE DRAWING		
	APPLICATION		
	NOT ASSY		
	ASSEMBLY		

Greentech Mfg. Inc.
 International Falls, MN
 P:866-361-7355
 F:218-283-5786

Pristine Series
 Wiring Diagram
 7200E 2023 Onwards

SIZE DWG. NO.

REV

7300E/7400E Electrical Wiring Diagram

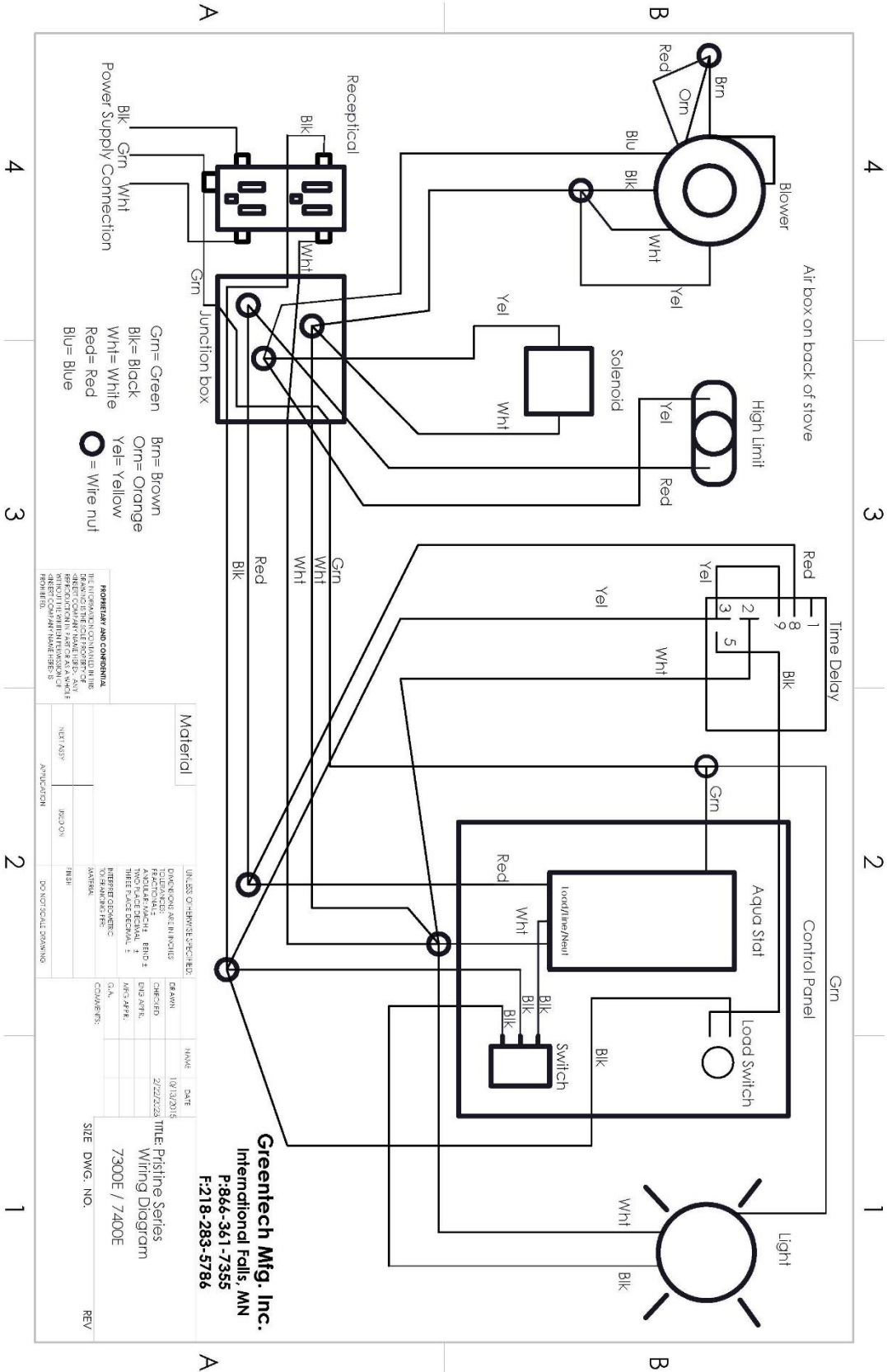

Smoke Troubleshooting Checklist For Outdoor Furnaces

- I. Installation Issues (Improper Smoke Dispersal)
 - A. Chimney height relative to nearest downwind neighbor
 - 1. If located 50 feet or less to any residence not served by the furnace, it is recommended that the stack be at least 2 feet higher than the eave line of that residence.
 - 2. If located more than 50 feet but no more than 100 feet to any residence, it is recommended that the stack be at least 75% of the height of the eave line of that residence, plus an additional 2 feet.
 - 3. If located more than 100 feet but no more than 150 feet to any residence, it is recommended that the stack be at least 50% of the eave line of that residence, plus an additional 2 feet.
 - 4. If located more than 150 feet but no more than 200 feet to any residence, it is recommended that the stack be at least 25% of the height of the eave line of that residence, plus an additional 2 feet.
 - B. Furnace located in sheltered area; insufficient wind to disperse smoke.
 - C. Furnace sizing. Similar to other heating appliances, furnace should be properly sized based on the estimated heat loss of the served structure.

- II. Fueling Issues
 - A. Burning less than optimal wood
 - 1. Moisture content: Optimal moisture content should be between 20% and 30% (seasoned wood)
 - 2. Species: Hardwoods generally tend to burn cleaner than softwoods
 - 3. Size: Larger pieces of wood tend to burn cleaner than smaller pieces
 - B. Burning less than optimal fuel loads
 - 1. Loading: Firebox should be loaded based on outdoor temperature, anticipated heat load requirements and the manufacturer's instructions. Do not overload the chamber.
 - 2. Charging intervals: Firebox should be charged regularly at the intervals specified by the manufacturer's instructions. Optimally, the firebox will be charged "hot," i.e., the fire will not go out between chargings.
 - C. Burning improper fuels
 - 1. Only burn fuels approved by the manufacturer
 - 2. Do not use volatile starters (such as lighter fuels, gasoline, chemicals) unless approved by the manufacturer
 - 3. Do not burn the following:
 - a. Trash or household garbage
 - b. Plastics

- c. Gasoline
- d. Rubber or tires
- e. Naphtha
- f. Material coated with petroleum products (e.g., particle board, railroad ties, pressure-treated wood)
- g. Leaves
- h. Paper products or cardboard

III. Operational Issues

- A. Improper combustion air – Natural Draft Units (No Blower):
 - 1. Air inlet not restricted by debris (creosote, ash, etc.)
 - 2. Flame baffle/flue not restricted by debris
 - 3. Chimney not restricted by debris
 - 4. Door seal in satisfactory condition (provides air-tight seal when door is shut)
 - 5. Air inlet (damper or flapper) operates properly (opens/shuts per manufacturer’s instructions, provides air-tight seal when shut)
 - 6. Door seal in satisfactory condition (provides air-tight seal when door is shut)
- B. Improper combustion air – Forced Draft Units (Blower):
 - 1. Verify combustion blower operates in accordance with the manufacturer’s instructions
 - a. Blower starts and stops properly
 - b. Combustion blower wheel spins properly
 - c. Blower runs at proper speed – verify voltage to blower motor
 - 2. Combustion blower tube not restricted by debris (creosote, ash, etc.)
 - 3. Flame baffle/flue not restricted by debris
 - 4. Chimney not restricted by debris
 - 5. Air inlet (damper or flapper) for blower operates properly (opens/shuts per manufacturer’s instructions, provides air-tight seal when shut)
 - 6. Door seal in satisfactory condition (provides air-tight seal when door is shut)
- C. Verify controls operate in accordance with the manufacturer’s instructions
 - 1. Water temperature controls set properly
 - 2. Draft controls set properly

IV. Maintenance Issues

- A. Verify that the furnace is being maintained in accordance with the manufacturer’s instructions. Specifically, inspect:
 - 1. Excessive ash buildup
 - a. Grates blocked, restricting air flow
 - b. Combustion fan blocked, restricting air flow
 - 2. Excessive creosote buildup
 - a. Combustion fan blocked, restricting air flow
 - b. Flame baffle blocked, restricting air flow
 - c. Chimney blocked, restricting air flow

V. Discussion

Wood, like other fuels is made up of various amounts of carbon, hydrogen, and other elements. The burning of wood is a chemical reaction that depends on many factors. The essential factors to complete wood burning are time, temperature, and turbulence. Some other factors to take into consideration are: intake air; amount and placement, density and moisture content of the fuel, size of the firebox compared to the size of the wood load, and adequate room for the combustion process to take place.

The smoke that is seen coming out of a chimney is essentially a combination of unburned fuel (carbon and hydrogen) and moisture in the form of water vapor. The reason for the smoke is usually attributed to: (i) not enough time for complete combustion, (ii) not enough mixing (turbulence) to complete the chemical process, (iii) not enough temperature to get the fuel to that chemical conversion stage, or (iv) a combination of the above. In many cases, excessive smoke can be reduced by adopting practices that improve complete combustion, reducing visible emissions in the form of smoke.

A. Fuel

1. Moisture Content

Moisture content of the wood, either too high or too low, will affect the amount of visible smoke. Wood with a low moisture content (less than 10%) will burn relatively quicker, resulting in some of the fuel going up the chimney in the form of smoke, i.e., time was insufficient to complete the burn process. Wood with a moisture content too high (more than 35%) can quench the flame causing smoke, i.e., temperature was insufficient to burn completely.

Wood moisture in the 20% to 30% range can be the best of both scenarios. It is dry enough to burn without quenching the flame, yet the moisture is high enough to self-regulate the burn, giving it plenty of time to complete combustion.

2. Density

The density of wood plays a part in the combustion process in the same way as moisture content. Softwoods are by definition less dense and tend to burn more rapidly than hardwoods. Softwoods tend to create more smoke – due generally to insufficient time to complete the burn. Denser hardwoods will burn more slowly and evenly, allowing more time for the conversion of fuel to heat.

3. Size

The size of the wood can also be a factor in the amount of smoke produced. The surface area of a piece of wood is one of the factors that will affect burn rate. Larger diameter logs tend to burn slower than smaller logs, allowing for a more complete burn.

4. Improper Fuels

Burning materials not recommended by the manufacturer can play a major role in visible emissions. Materials such as plastics, garbage, rubber tires, and even wood products such as cardboard and paper that may be coated with petroleum products may emit excessive smoke. Fire starters such as gasoline, oil, and other chemicals can also make an ordinary wood fuel load seem very dirty once burned. If people who own outdoor furnaces start fires with some kindling and load with wood fuel as recommended above, they can eliminate a lot of the smoke that others see and the problems that go with it.

5. Loading

The amount of wood loaded into an outdoor furnace in relation to the firebox size also has an effect on visible emissions. For every size of wood load there is a minimum amount of space needed to complete the combustion process. For instance, if a person were to load a relatively small firebox completely and load a larger firebox with the same amount of wood, with all of the other factors being the same, the larger firebox would burn cleaner. In the smaller firebox, the combustion process does not have enough room to expand, heat up, and mix before exiting the firebox (insufficient time, temperature, and turbulence). Just because a firebox is large does not mean that it should be filled completely. This large volume is used in part for what happens AFTER it is loaded.

B. Furnace Size

The size of a furnace should be large enough to provide sufficient heat without constant reloading. If the target burn time is 12 hours, an adequately sized furnace will provide enough heat for 90% of all heating days. There will always be the extraordinarily cold days for which no one can plan. A small furnace that needs constant reloading will unavoidably be left unattended and will lose much of its available heat. In these situations, the firebox is left relatively cold and restarting will be dirtier because of flame quenching on the cool firebox walls. A good rule to follow is be that if the furnace cannot stay within 20% of its set point under regular reloading, then it is undersized and a larger furnace is needed.

C. Chimney Considerations

Although chimney height has little to do with overall emissions, it should be considered in ALL installations of outdoor furnaces. Installers and dealers should first take a look at the proposed location and take a few things into account. Location of nearby buildings, structures, and natural geography all affect the furnace's ability to draft. While higher is generally better, it is sometimes tough to convince the furnace owner to add length to the chimney because of the extra cost.

VI. Conclusions

The proper use of an outdoor furnace can significantly reduce the visible emissions that it produces. Simple fuel considerations with regard to moisture content, size, and amount help hinder the production of smoke and ultimately help improve efficiency. Other obvious ways to

help reduce smoke is to only burn fuels recommended by the manufacturer and to not overload the furnace. In addition, the furnace size should be properly matched to the heat load so that cold starts and overfilling are avoided. Chimney height should be in accordance with the state and local codes, as well as surroundings, including neighbors. These areas, along with the “Best Burn Practices for Outdoor Furnaces,” can greatly help in providing clean, safe heat from all outdoor wood burning furnaces.

HPBA/JHGAdmin/102

Greentech Manufacturing, Inc. requires the usage of authorized furnace treatment to be used in all Crown Royal Stoves. Treatment is to be added to the furnace water upon initial startup and is required to remain at satisfactory levels throughout the life of the stove.

To ensure the maximum efficiency and longevity of your Crown Royal Stove, water treatment is crucial. Treating systems with authorized furnace treatment will prevent corrosion and scale buildup. Calcium and magnesium are commonly found in many water supplies. These impurities cause layers of scale that not only decrease heat transfer efficiency but cause pitting on the interior water jacket. Over time constant pitting will result in leaks. Once authorized treatment is added it creates the necessary barrier needed to prevent the breakdown of the metals. Premature corrosion is a result of not treating the water with correct corrosion resistant inhibitor or with the wrong dosage.

Water Treatment and Testing Required on all Crown Royal Stoves



All Crown Royal Stoves are required to be shipped with initial recommended gallon(s) of authorized treatment. Crown Royal Stoves are backed with a 20-year Limited Warranty. To retain warranty on Crown Royal Stoves it is required to use recommended treatment and submit annual samples for testing. Failure to maintain treatment at recommended levels and annual water testing will result in a voided warranty.

- Specifically designed for Crown Royal Stoves, closed-loop design.
- Helps protect system from scale, sludge and corrosion.
- Vapors help prevent corrosion throughout the furnace.
- Economical – one gallon/3.78 liters treats 300 gallons/1134 liters of system capacity.
- FREE Water Testing and sample bottles.

Sample Bottles

Two sample bottles and labels are found with each gallon of treatment. For additional bottles or labels please contact your local dealer or call 866-361-7355.

Warning

Read entire label located on treatment before opening or using this product. Keep out of the reach from children. Do not mix with any other chemicals. Contains Sodium Nitrate and Potassium Hydroxide. Avoid contact with skin, eyes and clothing. Undiluted product causes severe skin and eye irritations. Wash thoroughly after handling. Do not swallow. Swallowing may cause nausea, vomiting, weakness and lowered blood pressure. MADE IN U.S.A.

Storage

Keep fire-retardant closed container closed when not in use. When product is stored it may separate or thicken. This will not harm the performance. Before using, warm to room temperature and stir thoroughly. Keep from freezing.

Initial Start-up Procedure for Water Treatment

All Crown Royal Stove purchases are required to purchase authorized water treatment for initial start-up. With each gallon of treatment, you will be provided with two sample bottles and furnace information forms.

- Before adding treatment fill furnace with water and circulate for 48 hrs.
- Check for any leaks before adding treatment.
- Add initial dosages of treatment for the following model –
 - 7200E – Add 1 gallon
 - 7300E – Add 1 gallon
 - 7400E – Add 2 gallons
- Follow procedure for collecting water sample below.

Procedure for Collecting Water Sample

- Turn off furnace, and circulate for 24 hours to ensure complete mixture of water and treatment.
- Collection of sample can be done from drain line or other convenient location.
- Allow 30 seconds of drainage before collection of the sample.
- Use provided 4oz sample bottle to retrieve water sample.
- Fill out provided Furnace Information Form and attach to sample bottle.
- Mail water sample to designated testing facility found on provided Furnace Information Form.
- Testing facility analyzes the conductivity, PH and nitrate levels of water sample.
- Testing results are provided on all samples within 4-6 weeks.
- If testing results are unsatisfactory, recommendations of additional treatment will be given.
- These recommendations will need to be performed and a retest is required to maintain warranty.
 - Low levels – Additional treatment is to be added to system and a retest is required.
 - High levels – Water will need to be drained and replaced with fresh, untreated water and a retest is required.

When collecting water samples turn off the furnace and allow the water to reduce in temperature. When the water is reduced to a safe temperature, collect a sample.

WARNING!!! Hot water and surfaces may cause burns. Use extreme care with the collection of water sample.

Mailing Samples – Testing results are emailed to customers who provide emails on the Furnace Information form or mailed to the address give, within 4-6 weeks. It is owner's responsibility to ensure you receive testing results and follow recommendations. When mailing samples to testing facility, it is recommended to mail with tracking capabilities. If test results are not received within 4-6 weeks, please call 866-361-7355.

Additional Dosage Requirements

- If the system/furnace experiences a leak or requires water to be added, add treatment at the rate of ½ oz per gallon of water added.
- If the furnace system is drained for any reason, refer to initial startup procedure of Water Treatment.

IMPORTANT**Mandatory Yearly Maintenance Dosage and FREE Water Testing**

It is required annually to add treatment and send a water sample to our authorized testing facility to retain warranty of furnace. Water testing is free to all Crown Royal Stove customers for the life of the stove. **Failure to maintain treatment recommendation levels and submit annual water samples will result in a voided warranty.**

- Annually add ¼ of the required amount of treatment, this will keep levels balanced.
- Follow directions for collecting of water sample and mail to facility for testing annually.

Purchasing Water Treatment

Water treatment is specially formulated for Crown Royal Stoves. To uphold warranty no other chemical may be substituted. We encourage customer to contact your local dealership or call 866-361-7355 to purchase additional water treatment when needed.

For additional free sample bottles and labels please contact your local dealer or call Greentech Mfg at 866-361-7355.

**EMERGENCY FIRST AID PROCEDURES FOR FURNACE TREATMENT
EMERGENCY PHONE NUMBER
1-800-424-9300**

INHALATION:

Remove from the area to fresh air. If not breathing, clear the airway and start mouth to mouth artificial respiration. GET IMMEDIATE MEDICAL ATTENTION.

EYE CONTACT:

Immediately rinse the eyes with water. Remove any contact lens and continue flushing for at least 15 minutes. Hold the eyelids apart to ensure rinsing of the entire surface of the eyes and lids with water.
GET IMMEDIATE MEDICAL ATTENTION

SKIN CONTACT:

Wash affected areas with large amounts of soap and water for 15 minutes. Remove contaminated clothing and shoes. GET IMMEDIATE MEDICAL ATTENTION.

INGESTION:

Give 3 to 4 glasses of water, but do not induce vomiting. If vomiting occurs, give fluids again. GET IMMEDIATE MEDICAL ATTENTION. DO NOT GIVE ANYTHING BY MOUTH TO AN UNCONSCIOUS OR CONVULSING PERSON.

NOTE TO PHYSICIAN:

Introduction into the body may lead to the formation of Methemoglobin which in sufficient concentration causes Cyanosis. Since reversion of the Methemoglobin to Hemoglobin occurs spontaneously after termination of exposure, moderate degrees of Cyanosis should be treated only by supportive measures such as bed rest and oxygen inhalation. Thorough cleansing of all contaminated areas of the body including scalp and nails is of utmost importance. If Cyanosis is severe, intravenous injection of Methylene blue, 1MG/KG of body weight may be of value. Cyanocobalamin (Vitamin B-12), 1 MG intramuscularly, will speed recovery. Intravenous fluids and blood transfusion may be indicated in very severe exposures.

Thank you for making the choice to purchase your new Crown Royal Stove. We are certain that you will find great satisfaction with your stove's ongoing reliability and performance.

Greentech Manufacturing, Inc. warrants this furnace, to the original owner, to be free of defects in material and workmanship for a period of twenty (20) years from the date of purchase.

One Year Warranty

- On Electrical Components - Parts Only— aquastats, thermostats, fans and pumps are guaranteed by the manufacturer for a period of one (1) year from the date of purchase. Parts will be replaced on an even exchange, excluding shipping charges and labor.
- The loading & heat exchanger door, ash pan, door gaskets and ceramic moldings are warranted for a period of one (1) year from date of purchase.

Five Year Warranty

- Shaker Grates - the cast iron rocker grates are warranted for five (5) years 100%. This warranty excludes any warping or deterioration from ash corrosion.

If there is a leak in the fire box, water jacket or heat exchanger on your Crown Royal Stove during the:

- First (1) year - Greentech Manufacturing, Inc. will replace the unit at no cost to the original owner. The owner is liable for the un-installation of the old unit and the installation of the replacement unit.
- Two to five (2 - 5) years—If the unit is unable to be repaired and must be replaced the customer shall pay the difference between the original purchase price of the old unit and the new purchase price of the replacement unit, plus freight and installation.
- Sixth (6) year— Greentech Manufacturing, Inc. will pay a percentage of the total repair cost of the fire box and outer drum. Our percentage paid is as follows: year 6 –70%, year 7 – 50%, years 8-9 – 30%, years 10-20 – 20%. After the twentieth (20) year, Greentech Manufacturing, Inc. will give 10% off the purchase of a new stove.

Not Warranted

- Greentech Manufacturing, Inc. does not warranty parts damaged by freezing, overheating, pressurization, warping and/or use of unauthorized fuels or abuse.
- Greentech Manufacturing, Inc. is not responsible for the cost of plumbing, replacement of antifreeze, shipping, labor or any other cost other than the replacement of the part or furnace.
- Greentech Manufacturing, Inc. is not liable for any damage or cost which may occur from or during the operation of the furnace, or damage incurred due to any heating system failure. These furnaces are not intended to be the only source of heat; therefore, it is recommended that a back-up system is in place to prevent damages caused by lack of heat.
- No unauthorized adjustments or repairs will be covered by warranty.
- Greentech Manufacturing, Inc. does not warrant exterior paint or finish, any damage caused by negligence and deterioration due to lack of proper ongoing maintenance, overheating, physical damage caused by abuse or freeze up, unauthorized work or modifications to the furnace, damage to the fire-box due to power surges or damage caused by burning unauthorized fuels.
- Ash corrosion on the inside fire drum is not warranted. To prevent ash corrosion, rotating or raking ashes forward must be done as described in the manual. The Crown Royal Stove is designed to be the least susceptible to corrosion; therefore, most corrosion is covered under this warranty.

The chimney must be covered when the unit is not in use. It is mandatory that a chimney cap be installed before operation of the unit. If an onsite repair is made, the customer is responsible for the transportation costs and labor. If the furnace needs to be repaired at the factory, it is the responsibility of the consumer to pay all shipping charges to and from the factory. Greentech Manufacturing, Inc. specifically disavows any other representation, warranty, or liability related to the condition or use of this product.

The purchaser assumes all responsibility for the care, maintenance and safe operation of the furnace including the monitoring and adding of an approved boiler treatment. All instructions must be followed in the operator's manual, Control Chemical utilized and water samples tested annually and the warranty registration must be on file at Greentech Manufacturing, Inc. Greentech Manufacturing, Inc. always has the right to decide if the stove will be repaired or replaced. To qualify & validate this warranty, registration must be completed within thirty (30) days of purchase date, dealer's invoice attached and mailed to:

Greentech Manufacturing, Inc. • P.O. Box 1237 • International Falls, MN 56649

**Failure to use Control Chemical in your furnace and to send in annual water samples will void this warranty—
NO EXCEPTIONS!**

This Warranty is subject to change. For updated warranty information contact Greentech Mfg, Inc.

WARRANTY CLAIM FORM

Date: _____

Distributor/Dealer Name: _____

Address: _____

City: _____ State: _____ Zip: _____

Phone: _____ Fax: _____

Customer's Name: _____

Address: _____

City: _____ State: _____ Zip: _____

Phone: _____ Fax: _____

Claim conditions apply and cannot exceed warranty statement and procedure policy!
Please send this form, bill of sale and pictures back to service@green-techmfg.com. Claim cannot be processed without pictures and/or video of leak. Pictures cannot be blurry. Take close-ups and farther away so we can tell where the leak is happening. Warranty work completed without prior authorization may be denied.

(Process from start to finish - When reviewing all information sent in by customer, we make sure the stove is registered in original owner name and verify that the mandatory chemical was added to the system and yearly test results were sent in and came back satisfactory. When approved you find a local welder to give an estimate to repair the stove, which we approve and tell you the percentage covered. This warranty is prorated so it will be covered by a percentage. After you pay the bill you submit a copy to us and a check is submitted back to you. Complete process usually takes 30 days. Under some circumstances, we may require furnace to be shipped back to our facility.)

Model: _____ S/N: _____

Purchase Date: _____ Install Date: _____

Description of Claim: _____

Have you turned in a warranty claim before? Yes or No
If yes, is the leak in the same place? Yes or No

Additional Notes or Comments:

Repair Required:

PLEASE ATTACH PHOTOS OF AREA NEEDED REPAIR



16E09-101
 Universal Electronic Temperature Control
**INSTALLATION AND
 OPERATION INSTRUCTIONS**

Save these instructions for future use!

DESCRIPTION

The 16E09-101 is a single stage electronic temperature control, with a Nema 1 rated enclosure, and can be used for most applications within the temperature control range of -40° to 220°F, (-40° to 104°C). The control has an SPDT (Single Pole Double Throw) output load relay.

The control has user options to control differential, anti-short cycle delay, set back, offset, alarms and more. It includes an NTC (Negative Temperature Coefficient) thermistor temperature sensor, and can be used with certain other NTC or PTC (Positive Temperature Coefficient) thermistors that meet the specified resistance vs. temperature specifications. See the tables on page 7.

The control can fit many applications, which range from refrigeration to heating due to the wide temperature range of the control stated above. Typical applications include walk-in freezers, beverage coolers, supermarket display cases for flowers, produce, meats, convenience store refrigerated cases, food warmers, boiler control, and certain industrial applications.



PRECAUTIONS

! WARNING

- Failure to read and follow all instructions carefully before installing or operating this control could cause personal injury and/or property damage.
- To prevent electrical shock, personal injury and/or equipment damage, disconnect electric power to system at main fuse or circuit breaker box prior to installation or service.
- To prevent scald injury, do not use this control to heat water for bathing, washing, hot tub or similar applications.
- Where failure of this control may result in personal injury and/or property damage, additional alarms or limit controls must be installed.
- This control is a temperature control and is not to be used as a temperature limit control.

CONTENTS

Basic Description	1
Precautions	1
Installation	2
Wiring	3
User Menu	4
Operation	5
Specifications	7
Troubleshooting	8

16E09-101 Optional Accessories / Service Items:

Immersion Well	F89-0286
Replacement 7.5' NTC Remote Sensor	F136-0114
Well Heat Transfer Compound	F145-0163



www.white-rodgers.com
 www.emerson.com

PART NO. 37-6857G
 Replaces 37-6857F
 1016

INSTALLATION

- ⚠** To prevent electrical shock and/or equipment damage, disconnect electric power to system at main fuse or circuit breaker box prior to installation or service.
- ⚠** Where failure of this control may result in personal injury and/or property damage, additional alarms or limit controls must be installed.
- ⚠** This control is a temperature control and is not to be used as a temperature limit control.

The control has a user selection for changing the setpoint to be either the Cut In or the Cut Out setting. The user must be careful to understand how this effects the "range" in which the control will operate when the differential value is entered. If entered values are incorrect, the control could operate outside the user's intended settings due to set-up error. See section titled "Operation".

Fig. 1 Control Front View and Description

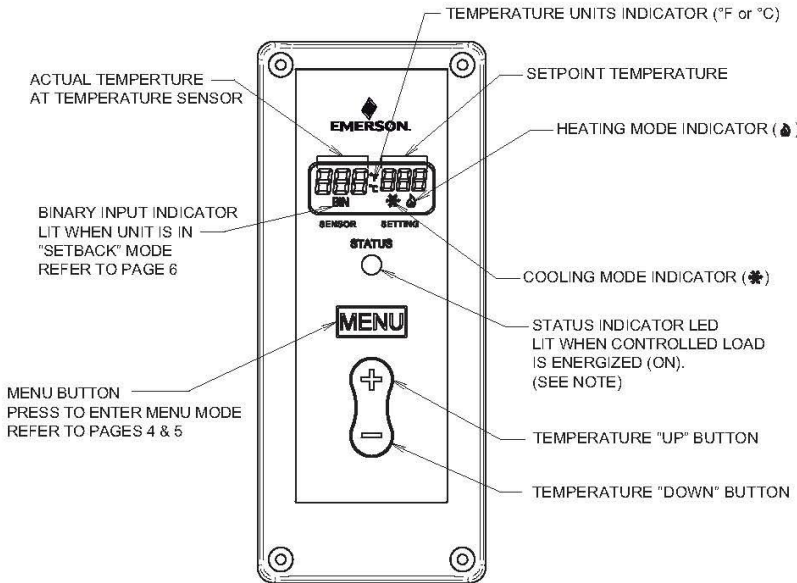

Circuit Board Inside Cover

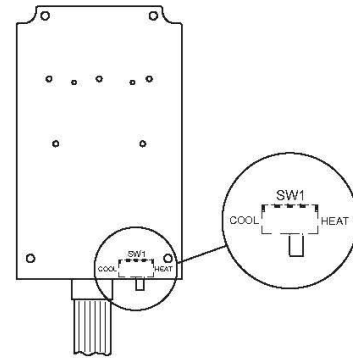

Switch SW1 must be set for system mode as shown:

	SW1
Refrigeration	Cool
Heating	Heat

NOTE:

Green Status Indicator LED and display backlight operation

It may be observed from time to time that the green status indicator LED and display back-light will briefly turn off during a call for heating or cooling. During this time, the control is performing a self-check lasting up to 15 seconds. This is normal operation of the control and the load power will be maintained

Fig. 2 Control Dimensions and Mounting Information

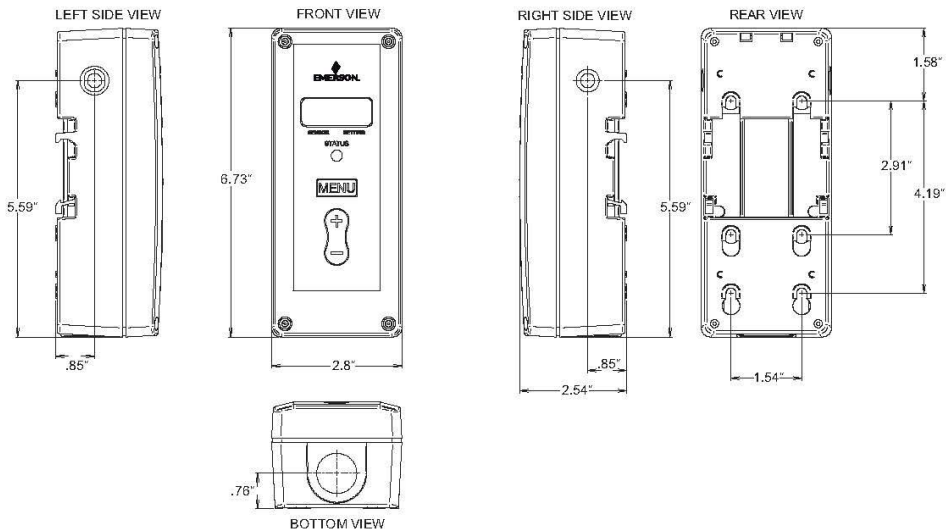

WIRING

Wiring Instruction Notes

Switch Settings

Switch SW2 must be set for applications as shown:

	SW2
Line Voltage (Power Stealing)	PS
Line Voltage (Non Power Stealing)	Non PS
24 VAC (Non Power Stealing)	Non PS

Power Stealing

Power Stealing is an electronic design within the control that can eliminate the need to connect a neutral line to power the control. The control receives power from the unit it is controlling. Power Stealing saves time and money by often eliminating the labor to run a neutral wire to the control for power. See compatibility chart below for certain limitations.

Power Stealing Compatibility Chart

Application	Power Stealing	Non-Power Stealing
Line Voltage, replacing existing control that has a common wire	Yes	Yes
Line Voltage, with load greater than 2.5 amps, without Defrost timer or other power interruption circuit, with or without alarm	Yes	Yes
Line Voltage, with load greater than 2.5 amps, with Defrost timer or other power interruption circuit, no alarm	See Note 1	Yes
Line Voltage with load greater than 2.5 amps, with Defrost timer or other power Interruption circuit, with alarm	No	Yes
Line Voltage with load less than 2.5 amps	No	Yes
24 VAC Application	No	Yes

NOTE 1: During defrost or time when load circuit is broke, display will be blank because power has been interrupted to the control. All menu settings and setpoint will be restored when power is returned.

* NTC – Negative Temperature Coefficient
PTC – Positive Temperature Coefficient

NOTE: Only one sensor (PTC or NTC) may be connected. Sensor must meet specific temperature vs. resistance specifications.

Fig. 3 Line Voltage Application (Power Stealing)

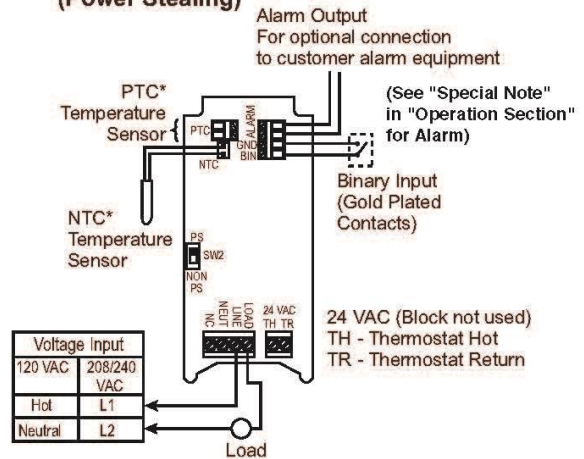

Fig. 4 Line Voltage Application (Non-Power Stealing)

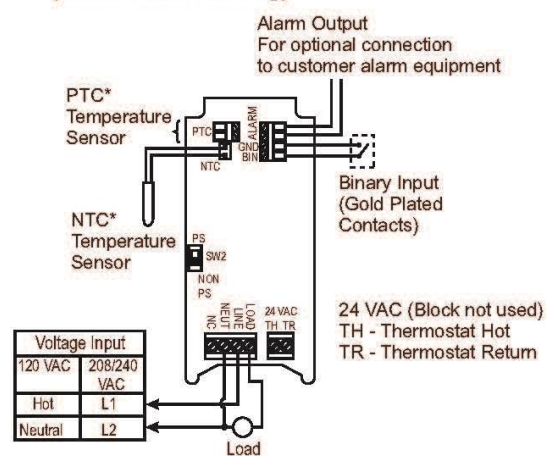
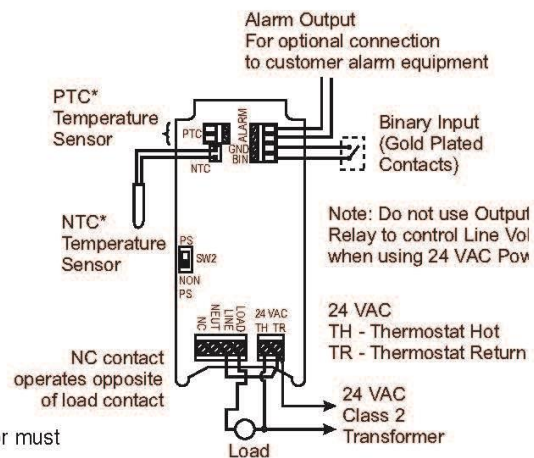

Fig. 5 24 VAC Applications (Non-Power Stealing)



USER MENU

USER MENU OPERATION SETTINGS:

The control has user Menu settings that will determine how the control operates. The unit is shipped with factory default settings. The user must change any of the settings as required for the application. To reset all settings to factory defaults, press and hold all 3 buttons simultaneously (MENU, +, and = buttons) for approximately 5 seconds.

To view Menu items, press and hold MENU for 5 seconds. The unit will display the first Menu item on the left side of the display. The right side of the display indicates the Menu item settings. To change the setting, momentarily press the + or = key.

A momentary press of the MENU key advances the display to the next Menu item, and continues, till the last menu item is displayed. Pressing the key one more time with the last menu item, (aL) displayed returns the control to the operating mode.

Each press of MENU results in forward movement to the next Menu item. If you need to change an item "passed", you must repeatedly press MENU, return to the operating mode, then press and hold MENU for 5 seconds to re-enter the Menu mode. Then repeatedly, momentarily press MENU until the desired Menu item is again displayed.

To store any changes made to any Menu items, the Menu must be exited by pressing MENU when the last item is displayed. If no buttons are pressed for ten minutes while in the menu, the control will return to operating mode and any changes that were made will be lost.

The following table shows the menu items, default settings and optional settings.

NOTE: The Heat/ Cool switch (SW1) MUST be in the proper position BEFORE setting options.

Menu Item	Description	Factory Default	Options Press + or = to select	Comments
CF	Temperature Scale	F	C or F	Selects temperature display in Fahrenheit or Celsius
dFF	Differential	5	1 to 30	Selects the range between Cut In and Cut Out.
SP	Set Point Mode Cool Heat	CI CO	CO or CI CI or CO	Selects how the set point temperature will operate the load terminal. CI indicates the setpoint temperature will be the Cut In temperature. CO indicates the temperature will be the Cut Out temperature. See Operation section.
SOF	Sensor Operation Failure Cool Heat	1 0	0 or 1 None	Cooling - Selects the operation of the Control Load relay in the event of a sensor failure in Cool mode. 1 (default) will cause the load contacts of the relay to close and remain closed if the sensor either opens or shorts. 0 causes the load contacts of the relay to open and remain open. Heating has no optional selection. Sensor failure in Heating will result in the relay contacts opening.
dL	Display Light	Off	On or Off	Selects the LCD display light Off or On. With this selected Off, the display light will illuminate any time a keypad button is pressed to provide better viewing in low lighting conditions, and go off after 10 seconds. If On is selected, the display light will be On continuously.
ASd	Anti Short-Cycle Delay	Cool 1 Heat 0	0 to 12	Selects the minimum time (in minutes) that the load contacts will remain open after a cycle before closing again. This will prevent the compressor or other load from being damaged by cycling too soon. A blinking Snowflake or Flame icon indicates that the control has a demand to energize the load, but is waiting for the delay time to elapse. A setting of 0 indicates no time and the feature is disabled. SW1 must be set to the proper position before checking this setting.
LP	Lock Front Panel Keypad	Off	On or Off	When selected Off, the keypad can be used as normal. When selected On, prevents unauthorized access to the control settings by locking out all keys. To unlock the control when it is locked, press and hold the Menu key for 5 seconds.
OFS	Ambient Temperature Offset	0	-4, -3, -2, -1, 0, 1, 2, 3, 4	This control is calibrated at the factory, but the "sensed" temperature may read different because of mounting/installation, or other factors. This item allows the displayed temperature to be shifted the number of degrees set to compensate for this difference

USER MENU

Menu Item	Description	Factory Default	Options Press \uparrow or \downarrow to select	Comments
bin	Binary Input	Off	On or Off	The default setting of Off will have no affect on the operation of the thermostat. When set to On, it allows an external binary input (switch or relay) to start a temperature set back. See Set Back (Sb).
Sb	Set Back	0	0 to 50	Selects the number of degrees the thermostat will change the setpoint temperature when the external binary input signal is received. 0 will cause no temperature change to occur. See Binary Input (bin).
AL	Alarm	0	0 to 99	Selects the time delay (in minutes) before a Temperature Out of Range alarm output is sent. A setting of 0 disables the alarm relay.

OPERATION

! This control is a temperature control and is not to be used as a temperature limit control.

! To prevent scald injury, do not use this control to heat water for bathing, washing, hot tub or similar applications.

The factory default setpoint for this control is 45°F (7°C) for Cool and 120°F (49°C) for Heat. Setpoint temperature can be adjusted using the \uparrow or \downarrow keys. A power loss does not lose the settings. All menu item selections and setpoint setting are stored in a permanent memory.

The user determines the temperature operating range. To determine the temperature range, the user must select the Set Point (SP) as the Cut Out or Cut In temperature, Differential (dFF) and enter a set point temperature. Cut out is when the load is turned off and cut in is when the load is turned on.

NOTE: The Heat/ Cool switch (SW1) **MUST** be in the proper position **BEFORE** setting options.

COOL/REFRIGERATION

To use as a Cooling control, SW1 must be set to Cool. The snowflake (❄) icon will display.

If control is in Cool mode, and Set Point is selected as the Cut In:

Temperature Operating Range = Setpoint Temperature - Differential (minus)

Example:

SW1 = Cool
Set Point (SP) = Cut In
Differential = 5
Setpoint temperature = 40°

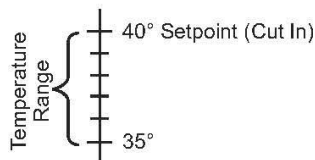

If control is in Cool mode, and Set Point is selected as the Cut Out:

Temperature Operating Range = Setpoint Temperature + Differential (plus)

Example:

SW1 = Cool
Set Point (SP) = Cut Out
Differential = 5
Setpoint temperature = 40°

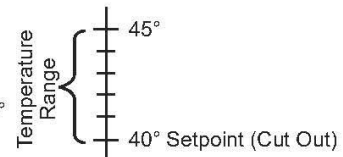

HEAT

To use as a Heating control, SW1 must be set to Heat. The flame (🔥) icon will display.

If control is in Heat mode, and Set Point is selected as the Cut Out:

Temperature Operating Range = Setpoint Temperature - Differential (minus)

Example:

SW1 = Heat
Set Point (SP) = Cut Out
Differential = 5
Setpoint temperature = 100°

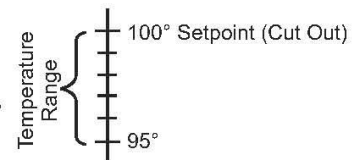

If control is in Heat mode, and Set Point is selected as the Cut In:

Temperature Operating Range = Setpoint Temperature + Differential (plus)

Example:

SW1 = Heat
Set Point (SP) = Cut In
Differential = 5
Setpoint temperature = 100°

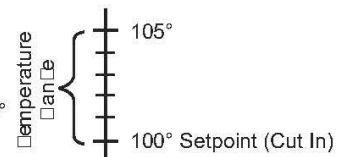

OPERATION

Lock Panel (LP)

The keypad can be locked to prevent unwanted tampering with the control settings. In the User Menu, change the menu item LP selection to On. When the menu is exited and settings are stored, the \leftarrow or \rightarrow , and **MENU** keys will be disabled from normal use.

To unlock the keypad, press and hold **MENU** for 5 seconds. The display will change to show LP On. Momentarily press \leftarrow or \rightarrow to change to Off and then momentarily press **MENU**. The control will return to normal operation and the keypad will be unlocked.

Binary Input (bln) and Set Back (Sb)

Binary Input is an option to allow the setpoint temperature to set back to conserve energy or for other reasons as determined by the user. Set Back determines the number of degrees the setpoint temperature will be changed.

An external switch or N.O. relay can be connected to the BIN and GND terminals of the control. With bln set to On, when the switch is closed, the control will change the setpoint temperature by the number of degrees set in Sb. In Heat mode, setpoint temperature will change lower or cooler. In Cool mode, setpoint temperature will change higher or warmer.

During the time that the switch is closed, bln will appear in the lower left corner of the display. If an alarm is connected be sure that the alarm delay time is set long enough to allow for the temperature change to avoid a "false" alarm.

Alarm (AL)

SPECIAL NOTE

Using the Alarm Output and power stealing in combination – When using power stealing mode and the alarm output, it is important for the installer to review the wiring circuit of the installation to insure no device is present that could interrupt electrical power to the temperature control. Such a device could be a defrost timer, as one example, that may be used in some refrigeration applications.

If a device is in the system wiring that can periodically disrupt power to the load and the temperature control, the power stealing mode of the control cannot be used. A neutral wire must be connected to the control and select the non power stealing mode for the control. This keeps power to the control during power interruptions to the load and avoids a "false" alarm output.

This control has an alarm relay that will provide an output to alert of a malfunction. The alarm relay output must be connected to an external light, audible alarm or other device as needed by the user. If AL is set to 0, the alarm relay will not provide any alarm output. If AL is set to a value greater than 0, the alarm relay output provides indication of three error conditions: Temperature Out of Range, Power Loss and Sensor Operation Failure. Although AL must be set to a value greater than 0 for any alarm output to be provided, the value selected is the time delay, in minutes, before a Temperature Out of Range alarm is set. The alarm time delay does not apply to Power Loss or Sensor Operation Failure.

Temperature out of range – If the temperature is more than 5° from the setpoint, continuously for the length of time set in AL, the alarm relay output will close. The delay should be set to allow for conditions that will cause the temperature to vary, such as defrost cycle, opening door for stock removal or replacement or Set Back changes. When setting the AL time, consideration should be given to these events to prevent a false alarm.

If the control set back feature is used to change the setpoint, the delay period set in AL should consider the time it takes for the system to reach the set back temperature to avoid a false alarm.

Power Loss – If the temperature control experiences an input power failure, the control will close the alarm relay before total power of the control is lost. The delay time is not used in this event, and the alarm relay will close within seconds of a power failure. In addition, the load relay contact change state per the Sensor Operation Failure (SOF) setting.

When power returns, the alarm contacts will open. The load relay will remain in the SOF position the length of time set in Anti Short-Cycle Delay (ASd) after power resumption. The display will blink the flame or snowflake icon for this time to indicate the load is "locked" out. This is to help protect the user's equipment from damage by short cycle switching.

Sensor Operation Failure (SOF) – If in operation, the sensor wiring should become open or shorted, the temperature control will begin blinking SOF with SH for shorted or SO for sensor open. However, the control will wait approximately 1 minute before closing the alarm output relay - indicating sensor operation failure. If during the 1 minute, the sensor "resumes" normal operation, the time is reset and the control returns to normal display. The load relay will operate as selected in sensor operation failure (SOF).

Multiple Sensors

The 16E09 is normally operated with one sensor. If an average temperature of an area is required, 4 sensors may be used and wired in the method shown below. If 4 sensors are used, they must all be of the same model.

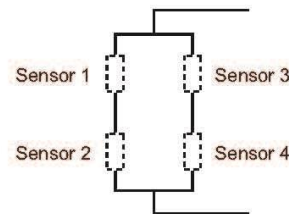

NOTE: When using multiple sensors, 4 sensors must be used. The control will not operate with 2 or 3 sensors.

SPECIFICATIONS

Load Output Relay:

Ratings (Maximum): 120VAC 208VAC 240VAC

Full Load Amps NC & Load	16 A	9.2 A	8 A
Locked Rotor Amps NC & Load	96 A	55.2 A	48 A
Non-Inductive Amps NC & Load	16 A	16 A	16 A
Horsepower NC & Load	1 hp	1 hp	1 hp

24 VAC NC & Load 100 VA, 30 VAC Max (Class 2)

Pilot Duty NC & Load 125 VA, 24 to 240 VAC

- Minimum Load Rating: 1 Amp @ 24 VAC
- Note: the above minimum current/voltage is specified to assure proper operation.

NOTE: For use on single phase circuits only.

Alarm Relay Ratings (Maximum):

N.O. contact: 1 Amp, 5 to 24 V, AC or DC

Operating Ambient Ratings (Control Enclosure):

Operating Temperature: -29°F to 140°F (-34° to 60°C)

Storage Shipping Ambient Ratings:

Storage Temperature: -40°F to 185°F (-40° to 85°C)

Operating Humidity: 0 to 95% Relative Humidity, Non-Condensing

Maximum Dew Point: 85°F (29°C)

Temperature Set-Point Range:

Set-Point Range: -40° to 220°F (-40° to 104°C)

Differential Range: 1 to 30 (Degrees F or Degrees C)

Case:

NEMA 1 Enclosure, Flammability Rating: UL94VO

Temperature Probes:

NTC

The control is shipped with an NTC (Negative Temperature Coefficient) sensor, with a cable length of 7½ feet. Cable length can be extended up to 400 feet by appropriately splicing and adding additional cable (22 AWG or larger diameter)

as needed – polarity is not important. When extending cable length, verify temperature accuracy and use the menu Ambient Temperature Offset (OFS) settings to compensate accordingly if required.

NTC TEMPERATURE VERSUS RESISTANCE TABLES

Temperature (°F)	Temperature (°C)	Resistance (KΩ)
-40	-40	328.29
-31	-35	236.83
-22	-30	172.90
-13	-25	127.65
-4	-20	95.23
5	-15	71.74
14	-10	54.56
23	-5	41.85
32	0	32.37
41	5	25.23

Temperature (°F)	Temperature (°C)	Resistance (KΩ)
50	10	19.82
59	15	15.67
68	20	12.48
77	25	10.00
86	30	8.07
95	35	6.55
104	40	5.34
113	45	4.38
122	50	3.61
131	55	2.99

Temperature (°F)	Temperature (°C)	Resistance (KΩ)
140	60	2.49
149	65	2.09
158	70	1.76
167	75	1.48
176	80	1.26
185	85	1.07
194	90	0.92
203	95	0.79
212	100	0.68
221	105	0.59

PTC

The control may be connected to an existing PTC (Positive Temperature Coefficient) sensor. Make sure the PTC sensor meets the specifications tables below. Failure to do so will result in temperature inaccuracies. The PTC input may not be

extended more than 50 feet, and the wire gauge should be 18 AWG wire or larger diameter. Be sure the probe attached matches the resistance vs. temperature tables or temperature inaccuracies may occur.

PTC TEMPERATURE VERSUS RESISTANCE TABLES

Temperature (°F)	Temperature (°C)	Resistance (KΩ)
-40	-40	613
-31	-35	640
-22	-30	668
-13	-25	697
-4	-20	727
5	-15	758
14	-10	789
23	-5	822
32	0	855
41	5	889

Temperature (°F)	Temperature (°C)	Resistance (KΩ)
50	10	924
59	15	960
68	20	997
77	25	1035
86	30	1074
95	35	1113
104	40	1153
113	45	1194
122	50	1236
131	55	1279

Temperature (°F)	Temperature (°C)	Resistance (KΩ)
140	60	1323
149	65	1368
158	70	1413
167	75	1459
176	80	1506
185	85	1554
194	90	1602
203	95	1652
212	100	1702
221	105	1753

TROUBLESHOOTING

LCD display, display back-light and green status indicator LED turn off in Power Stealing mode:

This "off" condition is normal for the control in power stealing mode when wired with a defrost timer or other device that interrupts electrical power to the control.

No control settings will be lost during this time, however, the installer must ensure that applications requiring power stealing are suitable for the control to be off during these periods.

Please note: if the built-in alarm feature of the control is to be used on systems that may interrupt power to the control, the control must be wired with a neutral wire and set in non-power stealing mode. This will keep the control continuously powered unless there is an actual power interruption or loss. In this case, the control will be able to signal an alarm for system power loss.

Display indicates "CaL" on power up.

Control was not calibrated. Return control for replacement.

Unit does not turn on, (LCD does not display anything):

- Check that wiring is correct.
- Make sure power is turned on.
- Check that wiring is under terminal blocks correctly.
- Make sure both switches inside control are set to proper position.
- If in Power Steal mode,
 - Make sure the load draws a minimum of 2.5 amp AC. If not, wire per the Non-Power Stealing diagram.
 - Make sure nothing "breaks/opens the load line, such as a defrost timer or any other device, with the alarm feature enabled. This would cause a false alarm. If the alarm function is enabled, wire per the Non-Power Stealing diagram.

Temperature differential is wider than set:

- Temperature change of customer's unit is fast, and the Anti Short Cycle delay setting may be overriding the "call" to activate the heat or cool. Solution – lower Anti Short Cycle delay.

Installation and Power Up:

False alarm sounds, temperature has not yet reached setpoint setting. CUSTOMER must disable alarm (AL = 0), until setpoint temperature is reached, then set alarm delay time.

Customer Changes Setpoint Temperature:

False alarm sounds. CUSTOMER must disable alarm (AL = 0), while unit is adjusting to new temperature. CUSTOMER must then set the alarm delay time when temperature is reached.

Bin/Set Back

False alarm sounds. CUSTOMER must set the delay time with sufficient delay time to assure the Set Back temperature is reached before the alarm delay time has expired.

Note: If the Set Back temperature cannot be reached within 99 minutes (the maximum Alarm delay time), change the Set Back value to a lower number of degrees. If a lower set back can not be used, you may not be able to use the alarm feature.

Alarm Sounds, Reason Unknown:

CUSTOMER should make sure the Alarm (AL) delay time is great enough to cover other conditions when the unit temperature may not be able to stay within 5 degrees.

- Loading or unloading of stock and the doors are open. (Add sufficient delay time to the alarm delay).
- Power is lost to the control if the line is broken/open by a defrost timer or other device. (Wire control per the Non Power Stealing line voltage schematic and connect/add a neutral line connection).

TECH SUPPORT HELP LINE: 1-888-725-9797

White-Rodgers is a division
of Emerson Electric Co.

The Emerson logo is a
trademark and service mark
of Emerson Electric Co.

White
Rodgers.

www.white-rodgers.com
www.emerson.com

EMERSON.
Climate Technologies

