

**THIS SPACE FOR DESIGNER/ENGINEER APPROVAL**

Job/Customer _____	Date _____	Contractor _____
Model Specified _____	Qty _____	Approved By _____
Designer/Engineer _____	Date _____	Contractor's PO# _____
Submitted by _____	Date _____	Other _____



**4067 Series**  
**T-Drain™**  
**Full Port Forged Brass Fitting**  
**w/ Hi-Flow Hose Drain**  
**IPS**  
**600 WOG**  
**ISO 9001**

ITEM #	SIZE	CTN	CASE	A	B	C	D
40672	1/2"	10	80	1/2	1 15/16	1/2	2 15/16
40673	3/4"	8	48	3/4	2 5/16	1/2	3 7/16
40674	1"	8	48	1	2 5/16	1/2	3 13/16
40675	1 1/4"	6	24	1 1/4	2 7/8	3/4	4 1/4
40676	1 1/2"	4	24	1 1/2	2 7/8	3/4	4 5/8
40677	2"	2	20	2	3	3/4	5 3/16



NO.	DESCRIPTION	MATERIAL
1	BODY	BRASS
2	END CAP	BRASS
3	SEAT	PTFE
4	BALL	BRASS HCP
5	STEM	BRASS
6	STEM SEAL	PTFE
7	PACKING GLAND	BRASS
8	HANDLE	ENAMEL COATED ALUMINUM
9	HANDLE SCREW	BRASS
10	CAP & STRAP	BRASS
11	WASHER	EPDM

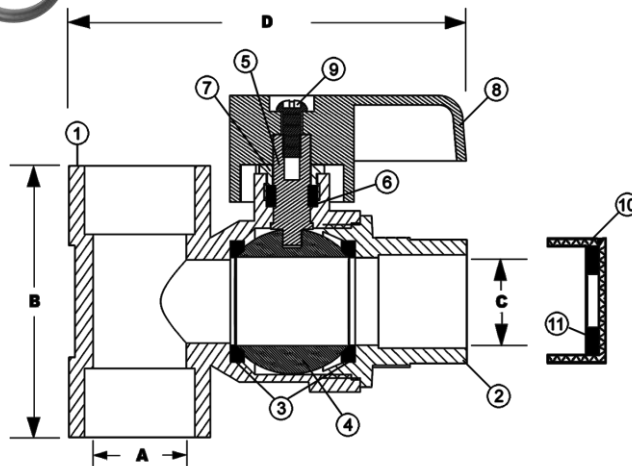

TEMP °F	WOG
100	600
150	490
200	470
250	439
300	411
350	294
366	N/A

**Specifications:** Designed for residential, commercial or industrial use with water, oil or gas. This approved Webstone valve is actuated by a blowout proof stem and features an adjustable packing gland. Threaded ends comply with ANSI B1.20.1.



Quality and Commitment Since 1954

Tel: (800) 225-9529 • Fax (800) 336-5133

Webstone product specifications in U.S. customary units are approximate and are provided for reference only. Webstone reserves the right to change or modify product design, construction, specifications or materials without prior notice and without incurring any obligation to make such changes and modifications on Webstone products previously or subsequently sold.